

Unical

MODULEX

360 - 450

540 - 630

**MODULAR CONDENSING
BOILER**



UNISERVICE KFT.

1106 Budapest,

Maglódi út 16.

TEL.: (06-1) 433 2612

FAX: (06-1) 431 8349



**INSTALLATION, USE AND
MAINTENANCE**



IMPORTANT

This INSTRUCTION MANUAL, which is an integral and indispensable part of the product, must be handed over to the user by the plumbers and must be kept in a safe place for future reference. The manual must be handed over with the boiler should it be sold or transferred.

This boiler must be used for the purposes for which it has been designed. Any other use shall be considered incorrect and therefore dangerous.

The boiler must be installed in compliance with applicable laws and standards and according to the manufacturer's instructions given in this manual. Incorrect installation may cause injury to persons and/or animals and damage to property. The manufacturer shall not be held liable for any such injury and/or damage.

Damage and/or injury caused by incorrect installation or use and/or damage and/or injury due to non-observance of the manufacturer's instructions shall relieve UNICAL from any and all contractual and extracontractual liability.

Before installing the boiler, check that the technical data corresponds to requirements for its correct use in the system.

Check that the boiler is intact and that it has not been damaged during transport and handling. Do not install equipment which is patently damaged and/or faulty.

Do not obstruct the air suction and/or heat dissipation grates.

Only original accessories must be used for all boilers supplied with optionals or kits (including electrical ones).

Dispose of the packaging with care as all the materials can be recycled. The packaging must therefore be sent to specific waste management sites.

Keep the packaging out of the reach of children as it may represent a choking and suffocation hazard.

In the event of failure and/or faulty functioning, switch off the boiler. Do not attempt to make repairs: contact qualified technicians.

Original parts must be used for all repairs to the boiler.

Non-observance of the above requirement may jeopardize the safety of the boilers and expose people, animals and property to danger.

To guarantee efficiency and correct functioning of the equipment it is legally binding to service the boilers once a year according to the schedule indicated in the relative section of this manual.

In the event of long periods of inactivity of the boiler, disconnect it from the power mains and close the gas tap (Warning! In this case the boiler's electronic anti-freeze function will not be operative).

Should there be a risk of freezing, add anti-freeze: it is not advisable to empty the system as this may result in damage; use specific anti-freeze products suitable for multi-metal heating systems.

N.B.

For boilers which use gaseous fuel, if you smell gas:

- do not turn on or off electrical switches and do not turn on electrical appliances;
- do not ignite flames and do not smoke;
- close the main gas tap;
- open doors and windows;
- **contact a Service Centre, qualified installer or the gas supply company.**

Never use flames to detect gas leaks.

WARNING

This boiler has been built for installation in the country indicated on the technical data plate: **installation in any other country may be a source of danger for people, animals and property.**

Read the warranty conditions and clauses on the warranty certificate attached to the boiler with care.

DATA PLATE

Unical®

1

S.N° 3 / 4

6

5

7 W - 8

Pn = 9 kW

Qn = 12 kW

PMS = 15 bar

PMW = 17 bar

Pcond = 10 kW

Qnw = 13 kW

T max = 16 °C

T max = 18 °C

D = 11 l/min

NOx 14

19				
2H	G20	20 - 25	mbar	<input checked="" type="checkbox"/>
2E	G20	20	mbar	<input checked="" type="checkbox"/>
3+	G30/G31	28-30/37	mbar	<input type="checkbox"/>
3B/P	G30 - 31	30 - 50	mbar	<input type="checkbox"/>
3P	G31	37 - 50	mbar	<input type="checkbox"/>

20		
IT ES IE	II 2H3+	20 ; 28-30/37 mbar
PT GR	II 2H3+	20 ; 28-30/37 mbar
TR HR	II 2H3B/P	20 ; 50 mbar
CZ SK	II 2H3P	18 ; 50 mbar
HU	II 2HS 3B/P	25 ; 30 mbar
SI	II 2E3P	20 ; 50 mbar
GB	II 2H3P	20 ; 37 mbar
CN RU RO	I 2H	20 mbar
LV EE LT	I 2H	20 mbar

21

- | | | |
|--|---|--|
| 1 = P.I.N. code | 9 = (Pn) Nominal Output | 15 = (PMS) Max pressure C.H. system |
| 2 = Boiler type (only for condensing boiler) | 10 = (Pcond) Condensing Nominal Output (only for condensing boiler) | 16 = (T max) Max Temperature C.H. system |
| 3 = (S.N°) Serial Nr. | 11 = (D) Specific flow rate EN 625 | 17 = (PMW) Max pressure D.H.W. system |
| 4 = Manufacture Date | 12 = (Qn) Nominal heat input | 18 = (T max) Temperature D.H.W. system |
| 5 = Model | 13 = (Qnw) Nominal heat input for D.H.W. system if there are different outputs between the C.H. and D.H.W. circuits | 19 = Adjusted for gas type X |
| 6 = Appliance type | 14 = (NOx) NOx Class | 20 = Country of destination, Gas category, Supply pressure |
| 7 = Electrical supply | | 21 = Side for national brand |
| 8 = Maximum absorbed power - Insulation protection | | |

1**TECHNICAL FEATURES**

AND DIMENSIONS	pag.	6
1.1 Technical Features	pag.	6
1.2 Dimensions	pag.	7
1.3 Technical Data and Main Components	pag.	9
1.4 Side View	pag.	10

2**INSTRUCTIONS FOR INSTALLERS**

INSTRUCTIONS FOR INSTALLERS	pag.	11
2.1 Instructions for installation	pag.	11
2.2 Installation	pag.	11
2.2.1 Packing	pag.	11
2.2.2 Boiler Location inside a Heat Power Plant	pag.	13
2.2.3 Boiler Connection	pag.	13
2.2.4 Connection to Chimney	pag.	13
2.2.5 Notes on Condensate Drain	pag.	14
2.3 Types of Heating Systems	pag.	15
2.3.1 C.H. System Air Vent	pag.	16
2.3.2 Boiler and System Filling-up & Draining	pag.	16
2.3.3 Max Allowable Working Pressure	pag.	17
2.3.4 Safety Valve	pag.	17
2.3.5 Gas Mains	pag.	17
2.3.6 Hydraulic Compensator or Open Manifold	pag.	17
2.3.7 Filter	pag.	18
2.3.8 Ball Valves	pag.	18
2.3.9 Feeding Water Quality	pag.	18
2.3.10 Boiler Antifrost Protection	pag.	18
2.3.11 Min. Water Flow Rate	pag.	19
2.4 Boiler Operation	pag.	19
2.4.1 General Description	pag.	20
2.4.2 Ignition Sequence	pag.	21
2.4.3 Supplementary Board	pag.	22
2.4.4 Domestic Hot Water (DHW) Mode Operation	pag.	23
2.5 Boiler Operation in case of technical intervention	pag.	23
2.6 Electric Connections	pag.	24
2.6.1 Power Supply	pag.	25
2.6.1 Wiring Diagram	pag.	25
2.6.2 Electric Connection to Ignition PCB	pag.	26
2.6.3 Electric Connection to the Room Thermostat	pag.	26
2.6.4 DHW Storage Tank	pag.	27

3**MODULAR BOILER DRIVE (MBD)**

OPERATION	pag.	28
3.1 General Description	pag.	28
3.2 Operation and display instructions	pag.	28
3.2.1 "Mode" Key	pag.	29
3.2.2 "Step" Key	pag.	29
3.2.3 "+ / -" Key	pag.	29
3.2.4 "Store" Key	pag.	29
3.2.5 Service Code	pag.	29
3.2.6 Programming Access Procedure	pag.	30
3.2.7 "Stand-by" Key	pag.	32

3.2.8	“Parameter” Mode	pag.	32
3.2.8.1	Installer and User programmable Operation Parameters	pag.	32
3.2.8.2	Installer programmable Operation Parameters by previously entering the service code	pag.	33
3.2.9	“Data” Mode	pag.	34
3.2.9.1	Installer and User programmable parameters	pag.	34
3.2.9.2	Installer programmable parameters by previously entering the service code	pag.	34
3.2.10	“Test” Mode	pag.	35
3.2.11	“Operation Time” Mode	pag.	35
3.3	Heating Mode Operation	pag.	36
3.3.1	Heating Mode Operation by Room Thermostat	pag.	36
3.3.2	Heating Mode Operation by Outer Sensor	pag.	36
3.3.3	Heating Mode Operation by Outer Compensator	pag.	37
3.4	DHW Mode Operation.	pag.	37
3.4.1	DHW Mode Operation by Storage Tank NTC Sensor ...	pag.	37
3.4.2	DHW Mode Operation by Storage Tank Thermostat	pag.	37
3.5	Burner Pressure Adjustment Test	pag.	38

4

ERRORS	pag.	39
4.1 Blank Display	pag.	39
4.2 The Boiler doesn't fulfill the DHW Production Request.	pag.	39
4.3 Ignition Anomalies	pag.	39
4.4 Block Errors	pag.	39
4.5 Error Codes	pag.	40
4.5.1 Error Codes by Alarm	pag.	40
4.5.2 Error Codes related to local temperatures	pag.	40
4.5.3 Error Codes related to gas pressure, MBD, AM-4 and AM-5	pag.	41
4.5.4 Error Codes related to global temperatures	pag.	41

5

MAINTENANCE	pag.	42
5.1 Main Features	pag.	42
5.2 Siphon Cleaning	pag.	42

1

GENERAL DESCRIPTION

1.1 - TECHNICAL / FEATURES

- MODULEX is a compact, gas fired, Low NO_x, condensing boiler, made up by one sectional boiler body (so called *heat module*), set to operate separately or in cascade. This heat module consists of two or more thermal elements (from 4 to 7), which cannot be separated from each other, being under the same protecting casing. These thermal elements are connected to a single smoke exhaust manifold and are controlled by a single microprocessor which manages completely the temperatures from the point of view, both operational and safety.
- If, for instance, one of the thermal elements whose the boiler is composed, goes out of order, the other thermal elements continue to supply their output. It is nearly impossible the boiler go completely out of order.
- MODULEX has been examined according the following European directives:
 - (GAD) Gas Appliances Directive No. 90/396 CEE
 - (BED) Boiler Efficiency Directive No. 92/42 CEE by CERTIGAZ, under the No. **1312BP4012**, for type **B23** operation, i.e. the boiler can be connected to a traditional natural draught chimney, and for operation in category I_{2H} (**G20** -20 mbar).
- It also conforms to the following European directives:
 - EMC (Electro Magnetic Compatibility) Directive No. 89/336 CEE
 - LVD (Low Voltage Directive) No. 73/23 CEE
 - Machines Directive No. 89/392 CEE
- The boiler body, made by sections of cast aluminium/magnesium/silicium alloy, is conceived to recover the sensible and the latent heat of the combustion gases, thus allowing to reach an efficiency of 109% on the N.C.V.
- Each thermal element, composed of a combustion chamber with burner, modulating fan with control pressure switch, gas valve, ignition device, flame control, NTC sensor for lo-

cal temperature control and safety thermostat, can deliver an output between a maximum of 90 kW and a minimum of 22 kW.

Thermal element No.	Model	Output range kW	Modulation ratio	Condensate production l/h
4	360	360 to 22 kW	1:16 (100 to 6,1 %)	60 l/h
5	450	450 to 22 kW	1:20 (100 to 4,9 %)	75 l/h
6	540	540 to 22 kW	1:25 (100 to 4,0 %)	90 l/h
7	630	630 to 22 kW	1:29 (100 to 3,5 %)	105 l/h

- Each single boiler is equipped with NTC sensors for global temperature control on the flow and return manifolds.
- Total premix modulating burner equipped with metallic sponge radiation burner. Premix in the pre-combustion chamber. Automatic no return diaphragm for separation from combustion chamber.
- Combustion air suction/feeding system from the boiler house
- Possible cascade installation of 2 or more MODULEX
- Heating Operation: setting of instantaneous output by a main microprocessor, with a comparison parameters pre-setting between the requested temperature (or calculated by the outer compensator) and the global flow temperature.
- Logic of operation:
 - A) Output sharing on as many modules as possible at min. load (down to 22 kW) for the max. efficiency.
 - B) Automatic operation hour splitting-up system for each module to guarantee the best homogeneous use.
 - C) DHW production by a priority sensor which, thanks to the dedicated electronic board, drives a special loading pump or a 3-way diverting valve for the preparation of a storage tank with the possibility of pre-setting the D.H.W. circuit output, up to maximum 360 kW.
 - D) Output check of each module for any calibration and/or assistance by secret access code.
- Control panel with alphanumeric display, programming keys, reset and hydrometer.
- Displays: global flow/return temperature, DHW temperature, external tem-

perature.

- Adjustments: flow temperature, fan speed, max/min. output percentage.
- Access to all testing/programming parameters of each module: operation test, operation time, boiler anti-frost protection from 7°C, pump's anti-blocking system.
- Integral easily removable panel set (painted steel panels).
- Condensate collecting tank equipped with drain siphon and stainless steel smoke chamber.
- Built-in air vent.
- Weights and dimensions are limited (see table at par. 1.2).

1.2 - DIMENSION

MODULEX 360

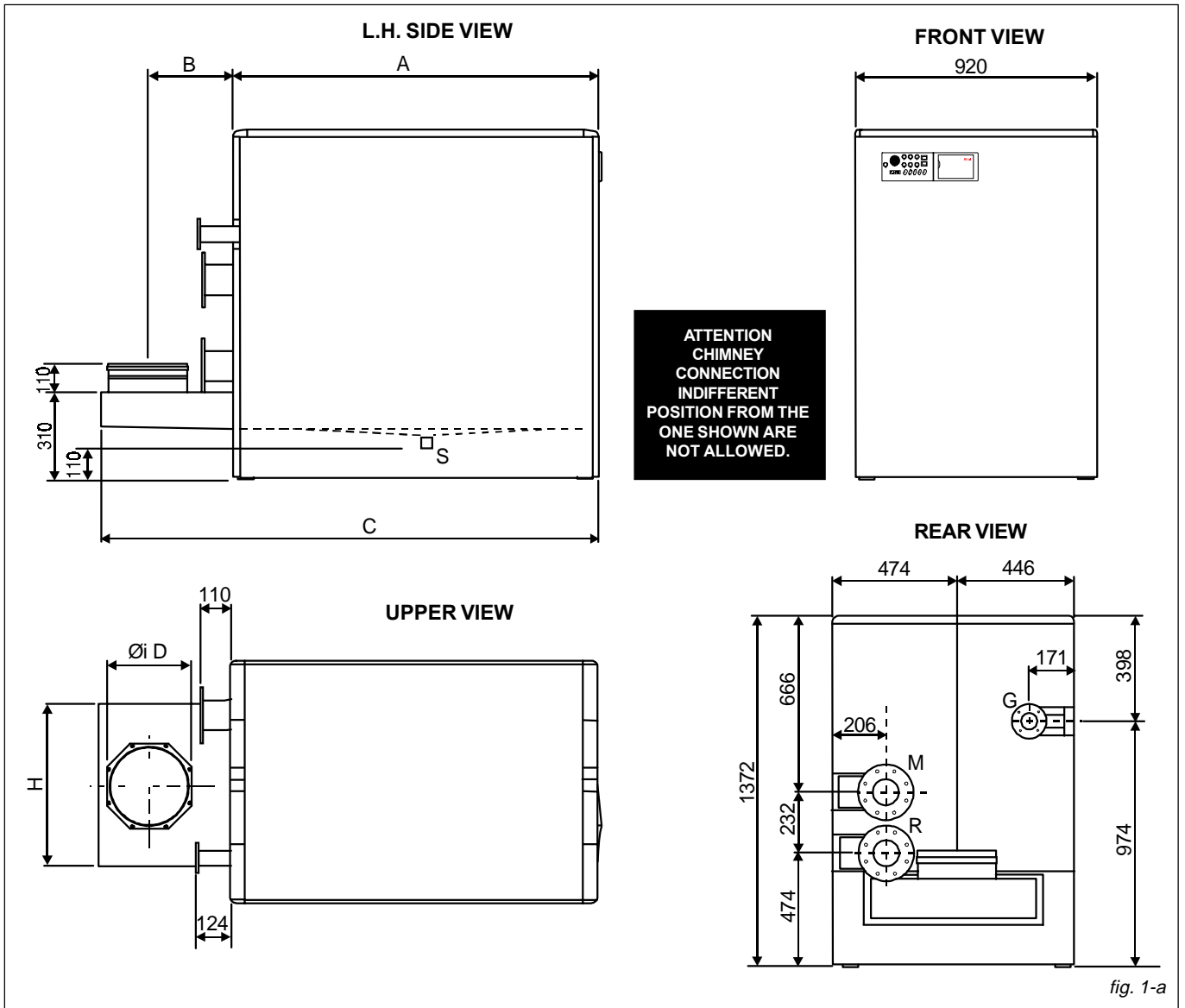

MODULEX		360
Dimension		
No. of Modules		4
Height	mm	1372
Width "L" net	mm	920
Width with packaging	mm	1020
Depth "C"	mm	1530
Depth "A"	mm	985
Depth "B"	mm	390
Depth with packaging	mm	1200
Net weight	kg	430
Gross weight	kg	496
Connections		
Gas	mm	DN50 PN 10/16
C.H. system Flow M	mm	DN80 PN 10/16
C.H. system Return R	mm	DN80 PN 10/16
Chimney connection "D"	mm	250
Chimney width "H"	mm	615
Condensate drain diameter	mm	40

MODULEX 450 - 540 - 630

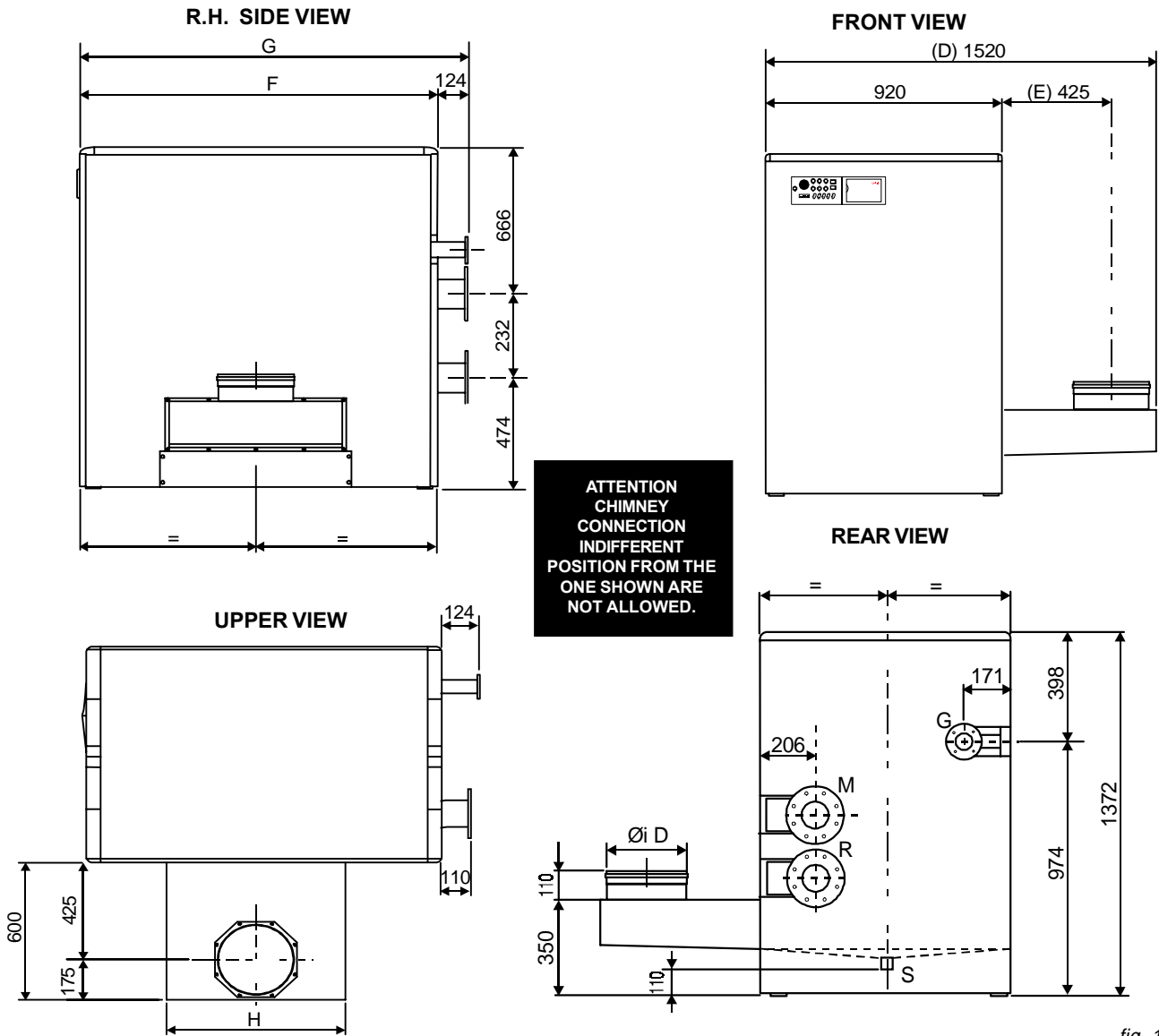

fig. 1-b

MODULEX		450	540	630
Dimension		5	6	7
No. of Modules		1372	1372	1372
Height	mm	920	920	920
Width "L" net	mm	1020	1020	1020
Width with packaging	mm	1520	1520	1520
Width "D"	mm	445	425	425
Width "E"	mm	1120	1256	1390
Depth "F"	mm	1320	1380	1514
Depth with packaging	mm	1340	1700	1840
Net weight	kg	510	620	680
Gross weight	kg	584	700	778
Connections				
Gas	mm	DN50 PN 10/16	DN50 PN 10/16	DN50 PN 10/16
C.H. system Flow M	mm	DN80 PN 10/16	DN100 PN 10/16	DN100 PN 10/16
C.H. system Return R	mm	DN80 PN 10/16	DN100 PN 10/16	DN100 PN 10/16
Chimney connection "D"	mm	250	300	300
Chimney width "H"	mm	615	720	855
Condensate drain diameter	mm	40	40	40

1.3 - TECHNICAL DATA

The Technical data plate is placed under the front jacket next to the control panel.

BOILER TYPE	MODULEX		360	450	540	630
Nominal Heat Input on P.C.I	Q_n	kW	360	450	540	630
Minimum Heat Input on P.C.I	Q_{min}	kW	22	22	22	22
Nominal Output (Tr 60 / Tm 80 °C)	P_n	kW	353,9	442,5	531,8	621,3
Minimum Output (Tr 60 / Tm 80 °C)	$P_n min$	kW	21,3	21,3	21,3	21,3
Nominal Output (Tr 30 / Tm 50 °C)	P_{cond}	kW	377,60	472,0	566,4	660,8
Minimum Output (Tr 30 / Tm 50 °C)	$P_{cond min}$	kW	23,80	23,80	23,80	23,80
Efficiency at max. output (Tr 60 / Tm 80°C)		%	98,30	98,33	98,48	98,62
Efficiency at min. output (Tr 60 / Tm 80°C)		%	96,82	96,82	96,82	96,82
Efficiency at max. output (Tr 30 / Tm 50°C)		%	104,89	104,89	104,89	104,89
Efficiency at min. output (Tr 30 / Tm 50°C)		%	108,18	108,18	108,18	108,18
Efficiency at 30 % at part load (Tm 50°C)		%	102,0	102,0	102,0	102,0
Efficiency at 30 % at part load (Tr 30°C)		%	109,2	109,2	109,2	109,2
Efficiency Class acc. to Directive 92/42 CEE			4	4	4	4
Efficiency Class acc. to Directive 92/42 CEE (100%)		%	98,10	98,29	98,45	98,59
Efficiency Class acc. to Directive 92/42 CEE (30%)		%	96,65	96,94	97,18	97,38
Combustion efficiency at nominal load		%	97,52	97,52	97,52	97,52
Combustion efficiency at part load		%	97,86	97,86	97,86	97,86
Stand-by losses (Q min.)		%	1,0	1,0	1,0	1,0
Stand-by losses (Q nom.)		%	n.r	n.r	n.r	n.r
Flue gas temperature (min)		°C	42	42	42	42
Flue gas temperature (max)		°C	50	50	50	50
Flue gas mass flow rate (min)		kg/h	36,6	36,6	36,6	36,6
Flue gas mass flow rate (max)		kg/h	583,0	728,7	874,4	1020,2
Excess of air λ		%	24,25	24,25	24,25	24,25
CO ₂ (min)		%	8,9	8,9	8,9	8,9
CO ₂ (max)		%	9,2	9,2	9,2	9,2
NO _x (value according EN 297/A3 + EN 483)		mg/kWh	62	62	62	62
NO _x class			5	5	5	5
Flue losses with burner in operation (min.)		%	2,48	2,48	2,48	2,48
Flue losses with burner in operation (max)		%	2,14	2,14	2,14	2,14
Flue losses with burner off		%	0,2	0,2	0,2	0,2
Min. water flow rate in CH circuit (ΔT 20°C)		l/h	16237	20296	24355	28414
Minimum pressure in CH circuit		bar	0,5	0,5	0,5	0,5
Maximum pressure in CH circuit		bar	6	6	6	6
DHW specific flow rate		l	73	88	103	118
Gas Consumption Natural gas G 20 (20 mbar) Q_n		m ³ /h	38,06	47,58	57,10	66,61
			-	-	-	-
Gas Consumption Natural gas G 20 (20 mbar) Q_{min}		m ³ /h	2,33	2,33	2,33	2,33
			-	-	-	-
Max. available pressure at the chimney base		Pa	100	100	100	100
Condensate production		kg/h	22,7÷60	28,3÷75	34÷90	39,7÷105
Emissions						
CO with 0% of O ₂ in the flue system		ppm	<35	<35	<35	<35
NO _x with 0% of O ₂ in the flue system		ppm	<35	<35	<35	<35
Sound level		dBA	<50	<50	<50	<50
Electrical data						
Voltage / Frequency		V/Hz	230 / 50	230 / 50	230 / 50	230 / 50
Fuse on main supply		A (F)	4	4	4	4
Max / Min absorbed power		W	540/41	675/41	810/41	945/41
Insulation degree		IP	40	40	40	40
Standby Consumption		W	10	10	10	10

1.4 - SIDE VIEW WITH MAIN COMPONENTS

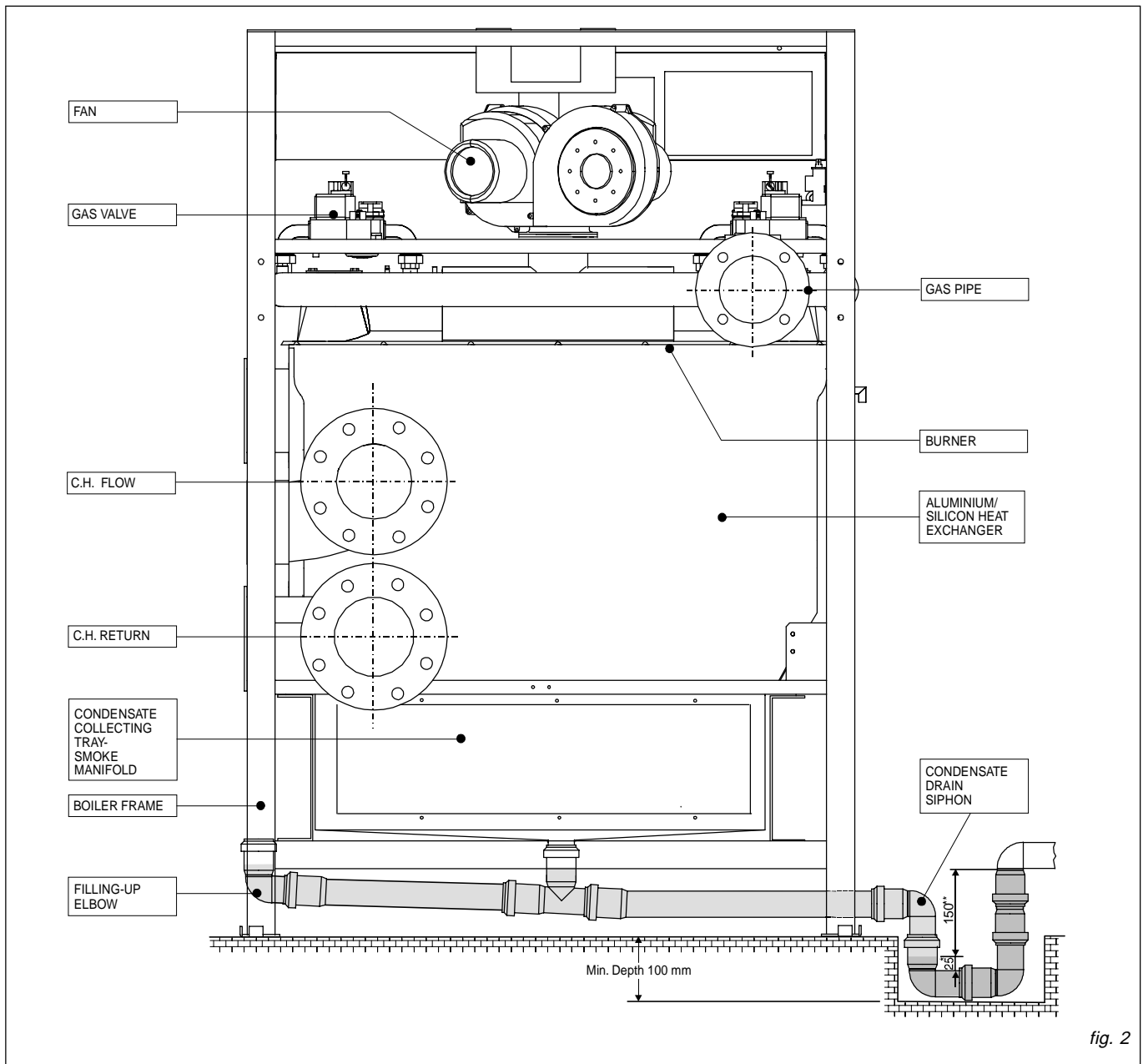

fig. 2

2.1 - COMPOSITION OF THE SUPPLY

- Boiler body made of sections of aluminium/magnesium/silicium alloy (5 to 8)
- Premix stainless-steel burner (4 to 7)
- Premixing chamber (8 to 14) with built-in non return valve
- Modulating fan (4 to 7) with air pressure switch control
- Gas valve (2 for each module – from 8 to 14) with separated flame control device SATRONIC (from 4 to 7)
- NTC sensors for local temperature control on each boiler section (5 to 8)
- NTC sensor for global flow manifold

- temperature
- NTC sensor for global return manifold temperature
- High Limit thermostat on each boiler section (5 to 8)
- Automatic air vent on the flow manifold
- Boiler draining/filling tap on return manifold
- Minimum gas pressure switch on gas manifold
- Condensate collecting tray
- Plastic pipe (1m) and fittings for condensate evacuation Ø40
- Smoke chamber terminal, with flue soc-

- ket:
- Ø 250 mm for models 360 and 450
 - Ø 300 mm for models 540 and 630
 - Integral painted steel casing
 - Modulation and control PCB (MBD) with PC interface
 - AM-4 PCB for DHW production and outdoor temperature sensor
 - Supplementary PCB type AM-5 (1 x mod. 360; 2 x mod. 450 and mod. 540; 3 x mod. 630)
 - Electronic card for interface
 - Outdoor sensor (into the smoke chamber)

2

INSTRUCTIONS FOR INSTALLERS

2.1 - INSTRUCTIONS FOR INSTALLATION

The MODULEX boiler is foreseen for the I_{2H} gas category and shall be installed in compliance with the latest regulations or rules in force.

2.2 - INSTALLATION

2.2.1 - PACKING

The MODULEX boiler is delivered into a strong carton box, complete of pallet (in order to easily transport the boiler up to the nearest point of installation place. The procedures for unloading the boiler are shown into the figure 3.

Remove both straps and finally the cardboard box from above, making sure the product is intact. The packing elements (cardboard box, straps, plastic bags, etc...) **shall not be left to children's hand since they may be dangerous.**

For the pallet removal is necessary to lift the boiler: it's necessary to use a jib crane (like shown into the figure 3), in order to avoid of damage the pressure switches, gas valves or electric cables.

- Remove the jacket and prepare the sling with the bands "A" (fig. 3) by taking care of let the bands pass internally of flow, return and gas manifolds.
- Bind the bends to the jib; during this step be particularly careful.

Inside the packing,
on the rear part of the boiler, for Modulex 360 – 450
on the front part of the boiler, for Modulex 540 – 630
you can find the smoke chamber, containing:

- a plastic bag containing:
 - 3 gaskets (1 rectangular between condensate tray and flue terminal, 1 square between flue socket base and flue terminal and 1 for flue socket Ø 250 or Ø 300 mm according to the model
 - 2 bends + 1 Tee piece + 1 plastic plug, Ø 40 mm for condensate drain.
 - the screws necessary for fixing
- A plate for the jacket closing, only for models 540-630
- The outdoor sensor
- The siphon pipe for condensate drain

on the L.H. side of the boiler:

- the R.H. side panel connected to the L.H. side one by a thermoretractable film.

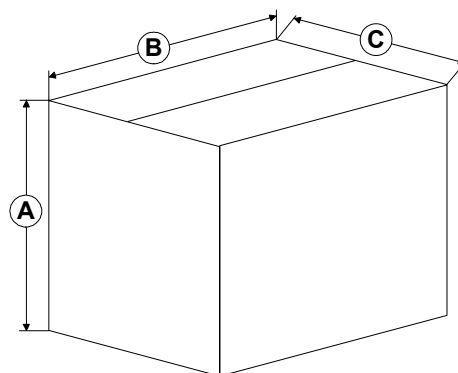

DIMENSIONS	A	B	C
modulex 360	1650	1200	1020
modulex 450	1650	1550	1020
modulex 540	1650	1700	1020
modulex 630	1650	1840	1020

on the boiler top:

- a plastic bag containing:
 - This instruction manual
 - Warranty certificate
 - Hydraulic certificate

fig. 3

BOILER UNLOADING AND PACKAGE REMOVAL

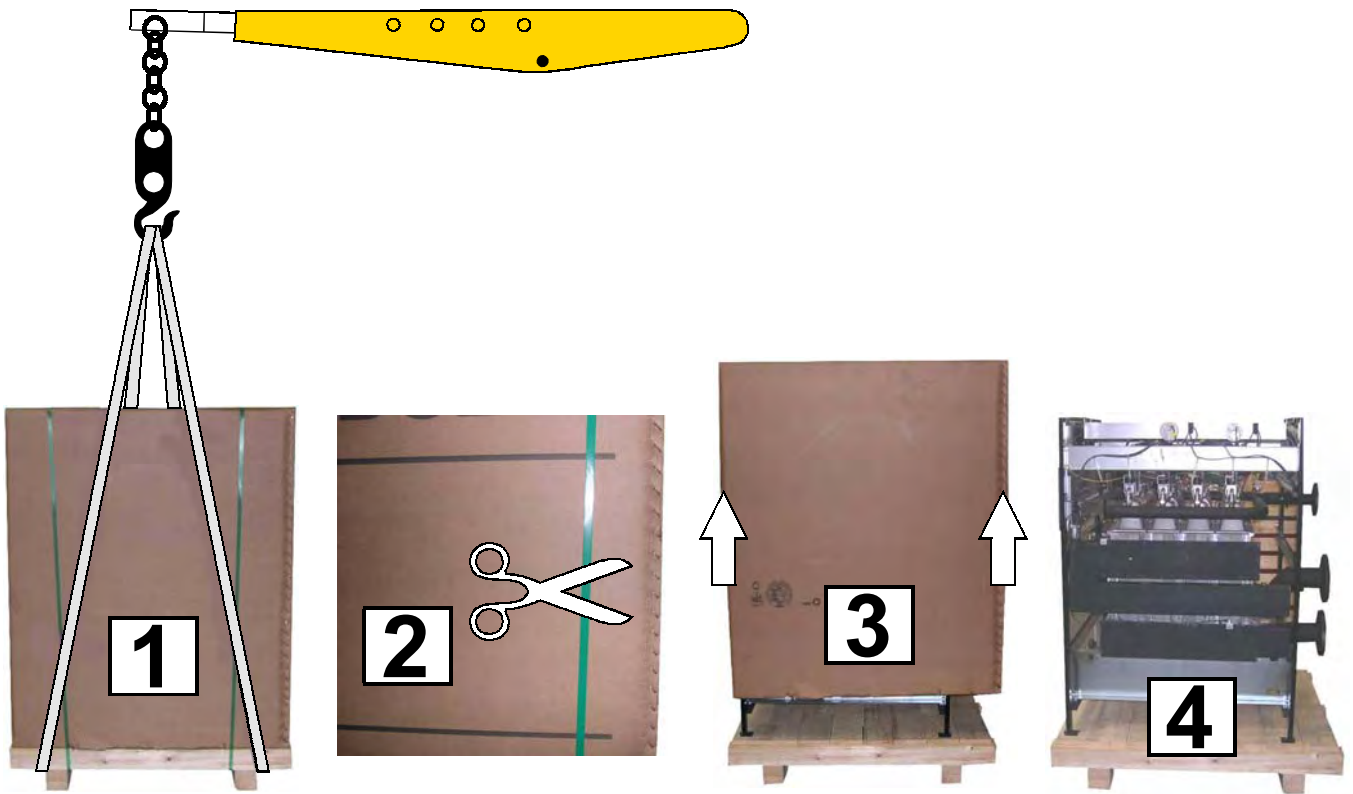

PALLET REMOVAL

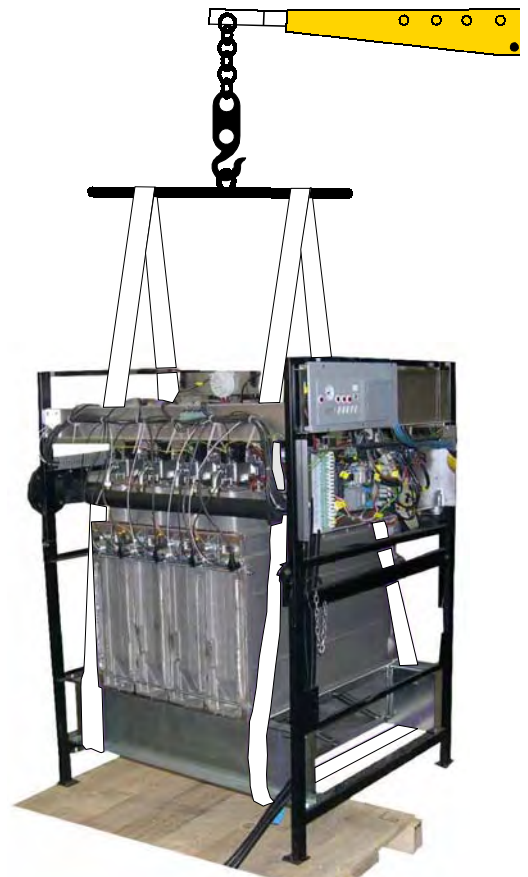
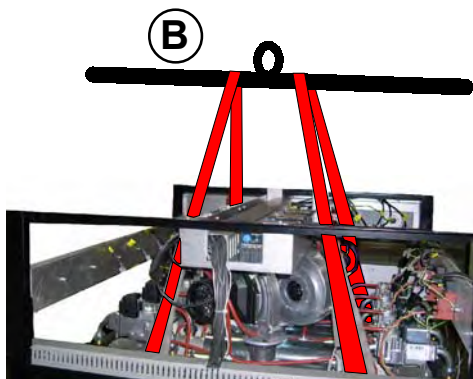
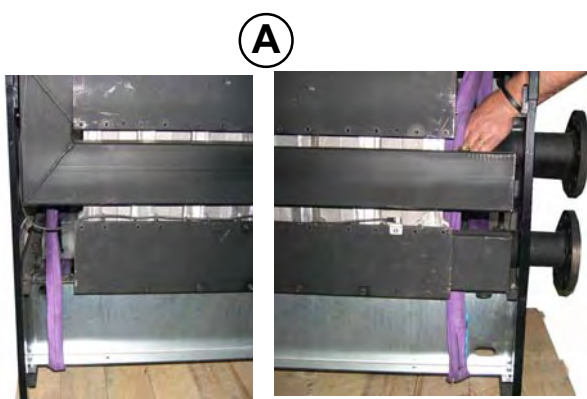

fig. 4

2.2.2 - BOILER LOCATION INSIDE A BOILER HOUSE

Special attention shall be paid to local regulations and laws about boiler houses and particularly to the obligation of keeping minimum clearances and empty space around the boiler. The installation shall be in compliance with all latest regulations and laws about boiler houses, installations of heating and hot-water systems, ventilation, chimneys capable of evacuating the flue gases of condensing boilers and any other applicable requirement.

When selecting the position for the installation of the boiler it has to be considered that, for the cleaning and washing operations of the boiler body, one of the boiler sides must be accessible for the removal of a special baffle placed under the aluminum sections.

The boiler can be put on a flat and sufficiently strong base with the same dimensions as the boiler ones and at least 100mm high (see fig. 5), in order to assemble the condensate drain siphon. An alternative to this base may be a 100 mm deep well next to the boiler as siphon housing (see fig. 2). After installation the boiler shall be perfectly horizontal and stable, to reduce any possible vibrations or noises.

2.2.3 - BOILER CONNECTION

The boiler Modulex leaves the factory pre-disposed for the hydraulic and gas connection on the back side of the boiler. The smoke outlet is placed on the back side

of the boiler for MODULEX 360; it's placed on the R.H. side of the boiler for MODULEX 450 - 540 - 630.

For the smoke chamber fixing, use the

screws and gaskets included into the instruction bag, and a cross screwdriver at least 300 mm of length.

2.2.4 - CONNECTION TO THE CHIMNEY

**ATTENTION:
BEFORE ASSEMBLING THE CHIMNEY DUCT IT'S ABSOLUTELY NECESSARY TO SET A SUPPORT UNDER THE SMOKE CHAMBER TERMINAL**

Into a condensing boiler, the smokes reach a very low temperature (Max 84°C). So, it's necessary that the chimney is perfectly impermeable to condensation of combustion products and built with materials corrosion resistant.

The various spigot joints have to be well sealed and endowed with provided for

gaskets, so that to prevent the condensation spillage and the air entry.

For the chimney dimensioning, diameter and height, it is necessary to make reference to the national and local regulations. In order to avoid, during the operation, the ice formation, the temperature of the inside wall in every point of the system for the combustion products evacuation, for all of its length, doesn't have to be lower than 0°C.

For operation in condensing conditions with the outdoor temperature of project, it will be therefore necessary the realization of a system of confluent condensation drain, according to the installation conditions, in the collection box of the boiler or separated by it.

Model	Modules No.	Flue diam.
360	4	250
450	5	250
540	6	300
630	7	300

2.2.4.1 - MATERIALS FOR FLUE PIPES

As material can be used the stainless steel AISI 316 L or AISI 316 Ti, with a minimum wall thickness of 0.4 mm, or the aluminium, with a minimum wall thickness

of 1.5 mm, or the PVDF (Polyvinildimethylfluorure), or the PPS (Simple transparent polypropylene), certified for this use. Other materials and thicknesses are also admitted, provided they guarantee at least equivalent characteristics.

In case of tubing of an existing chimney

the flue pipe has to be of aluminium (min. thickness of 1.5 mm) or of stainless steel (min. thickness of 0,4 mm) and its connections have to be water proof.

2.2.5 NOTES ON CONDENSATE DRAIN

Avoid the condensate stagnation inside the combustion products evacuation system, (for this reason the evacuation duct must have an inclination toward the drain of at least 30 mm/m) except the liquid column, inside the condensate siphon (which needs to be filled with water after installation: its minimum height, when all the fans are in operation, must be at least 25 mm).

In order to avoid ice formation while the

boiler is operating, which can cause the stop of the boiler, the whole condensate evacuation system has to be well insulated. It is forbidden to evacuate the condensate through a gutter: risk of ice formation and corrosion.

The condensate, before being evacuated to the sewer, has to be neutralised, neutralization which can be obtained by mixing the drain water coming from washing machines, dish washing ma-

chines, etc., which normally have a basic pH. The connection to the sewer will be through a visible drain. Given the high acidity degree (pH 3 to 5) only plastic materials can be used for the condensate evacuation pipes. Moreover it must be dimensioned and constructed so as to allow the correct outflow of drains preventing any bottleneck and any leakage.

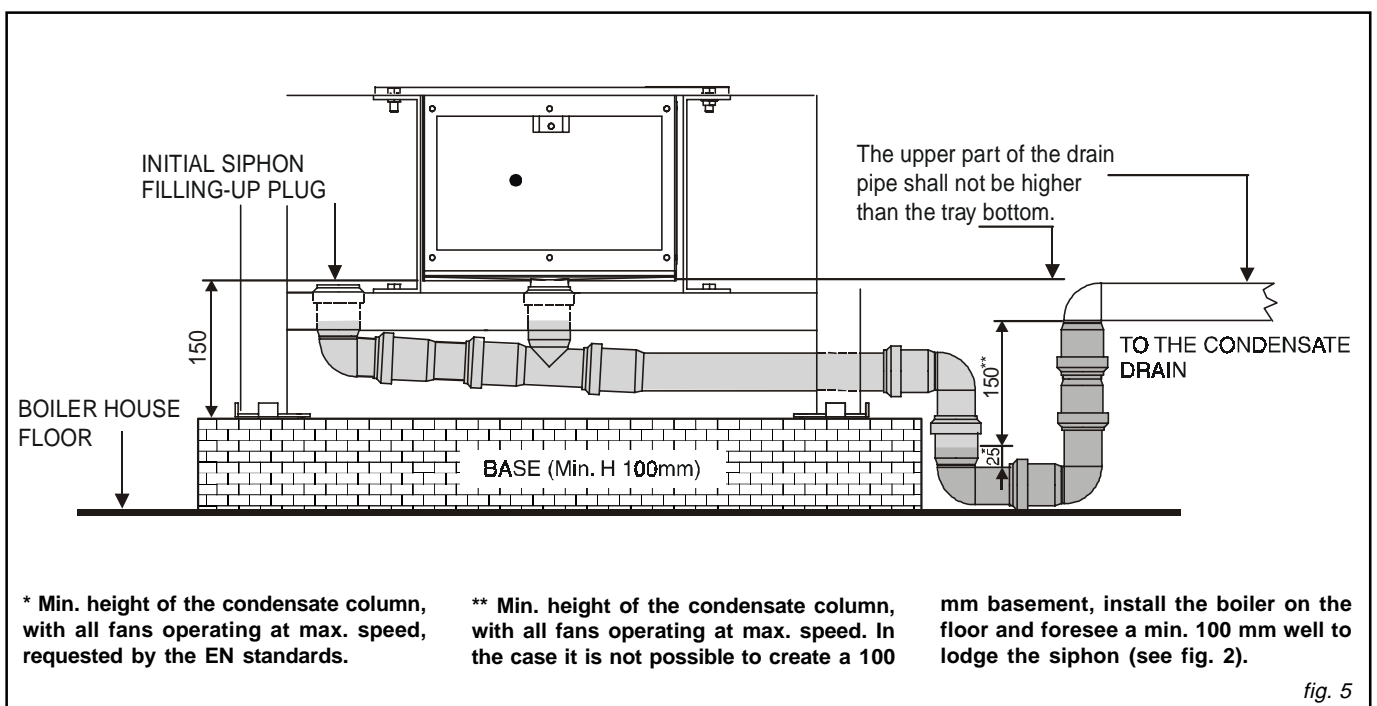

2.2.6 - WATER TREATMENT

If the installation needs a water treatment the following conditions are to be respected:

- the pH, for boilers with aluminium alloy body, **must always be within 6.5 and 8;**

- all precautions will be taken to avoid the formation and localisation of oxygen in the water of C.H. systems. For this reason it will be necessary that in the C.H. systems using floor radiant heating, the plastic pipes used are impermeable to the oxygen;
- in case of utilisation of anti-frost so-

lutions, their compatibility with aluminium alloy and other components of the C.H. system has to be ascertained.

2.2.6.1 - REPLACEMENT OF AN EXISTING BOILER BY A MODULEX

In case of installation of a MODULEX on an old C.H. system we recommend to purge and to rinse properly the whole system before connecting the new boiler. To avoid misunderstandings it is sug-

gested to interpose between the boiler and the system, a plate heat exchanger. On the contrary, in case of installation of a MODULEX on a new system we recommend to make a simple water rinse of the

whole system and to fit a Y filter on the return pipe to the boiler, equipped with gate valves.

2.3 - EXAMPLES OF HEATING SYSTEMS

The following system figures are to illustrate some, but not all types of heating systems.

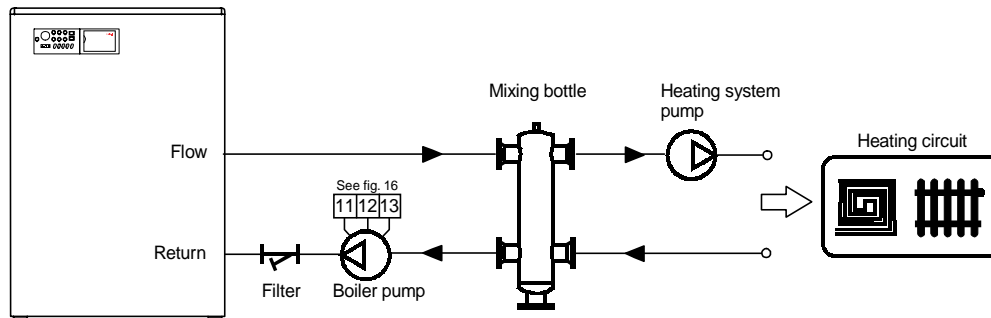

Fig. 6.1 Heating system with one group of radiators.

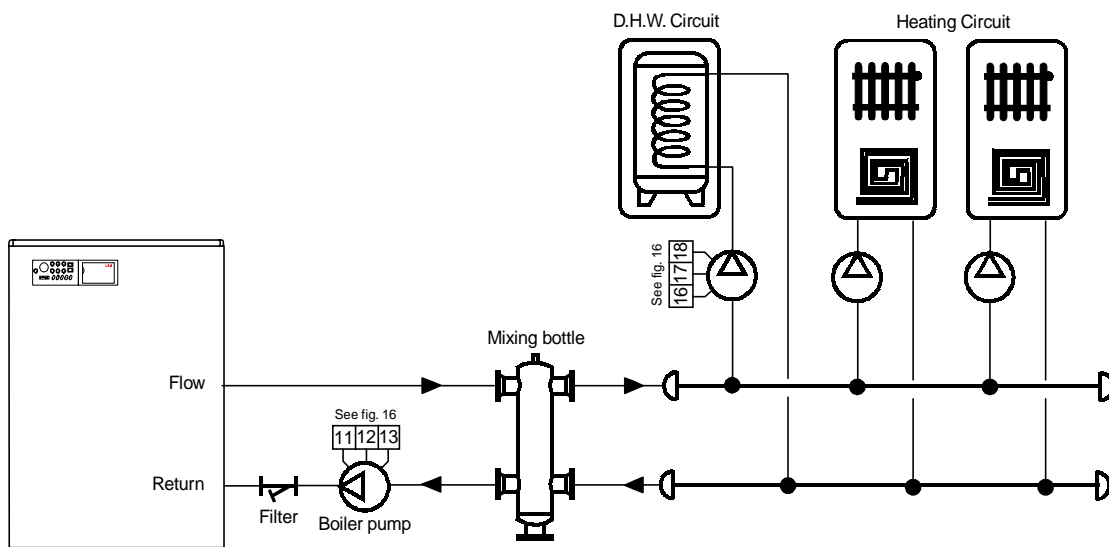

Fig. 6.2 Installation of a boiler with a mixing bottle and connection to a heating circuit with DHW production (storage tank output < or = boiler output).

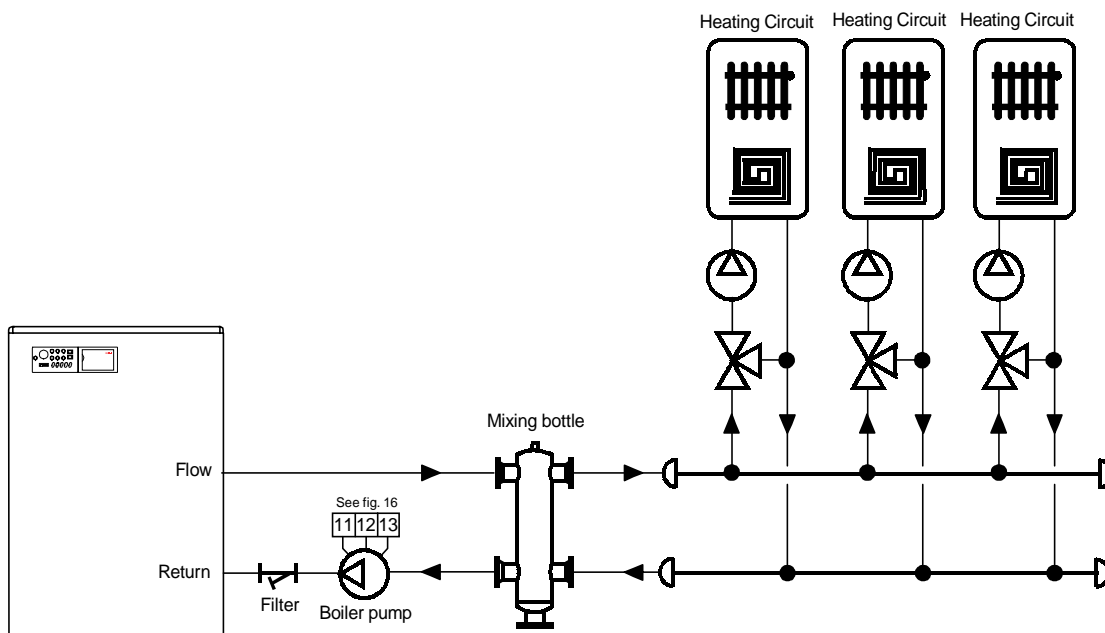

Fig. 6.3 Heating system with mixing bottle and flow temperature control by an outer compensator. More radiator groups are controlled by a dedicated outer compensator. The heating curve of the boiler outer compensator has to be adjusted at 5 K above the temperature of the radiator group working at the highest temperature.

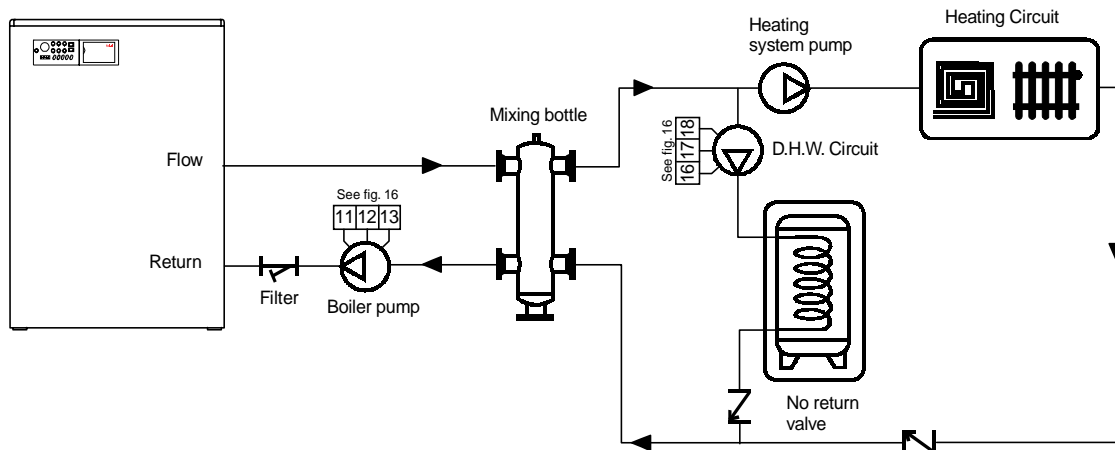

Fig. 6.4 D.H.W. storage tank with loading pump installed on the secondary circuit, in parallel with the heating circuit.
Note: The Pr pump (heating pump) shall be off while the storage tank pump is running. In this case, the second digit of parameter A shall be set to 2 (three-way valve).

For the connection of a boiler pump on the primary circuit or of a storage tank loading pump or a three-way valve, convenient information can be found in the following table, which indicates the terminals supplied with 230 V in the different hypothesis.

Is there any heating demand?	YES/ NO	YES / NO	YES / NO	YES	NO
Is there any D.H.W. demand?	YES	NO	YES	NO	NO
D.H.W. priority system configuration depending on 2 nd figure of "A Parameter" (see paragraph 3.2.8.2)	230 V - 50 Hz tension is present at terminals 16 - 18		230 V - 50 Hz tension is present at terminals 11 - 13		
parameter A = x 0 _{2nd figure}	YES	NO	YES	YES	NO *
parameter A = x 1 _{2nd figure}	YES	NO	NO	YES	NO *
parameter A = x 2 _{2nd figure}	NO	YES	YES	YES	NO *

The terminals 11 –13 will be supplied on tension 230 V in the case the pump after running is activated.

2.3.1 - VENTING OF THE C.H. SYSTEM

An effective air vent shall be foreseen in the highest point of the system. Inside

the boiler, there is an automatic air vent on the flow manifold (see fig. 2). **This air**

vent is foreseen for the boiler, not for the whole system.

2.3.2 - BOILER AND HEATING SYSTEM FILLING-UP & DRAINING

For filling-up the system a filling tap has to be foreseen on the system return pipe.

In both the cases, an approved hydraulic disconnection system has to be fitted.

Before connecting the boiler, carefully rinse out the whole system by running water.

tem, since the system dirt could gather in the boiler and compromise its operation. The system itself shall be equipped with its own draining tap, whose size depends on the system capacity. The application of a filter on the return pipe to the boiler is advisable.

The filling-up can also be made through the draining tap on the boiler return manifold.

The boiler is equipped with its own draining tap (see fig. 2 for its position). Never use such a tap to drain the sys-

2.3.3 - MAX ALLOWABLE WORKING PRESSURE

The boiler max allowable working pressure is 6 bar, while the min. one is 0,8 bar.

The boiler does not have any special protection device against water lack,

since this function is carried out by the safety thermostats of the modules with timeliness. However, the installation of a min. pressure switch as well as its electric connection are foreseen (1/4" con-

nection on the return manifold and electrical in series connection on the min. gas pressure switch terminals).

2.3.4 - SAFETY PRESSURE RELIEF VALVE (not supplied)

A safety valve dimensioned for the system capacity and in compliance with local regulations in force shall be installed

on the flow pipe (within 500 mm from the boiler).

2.3.5 - GAS MAINS

Due to the presence of a min. gas pressure switch, the gas main diameter shall be calculated carefully. Even though the

gas valves have their own filter, UNICAL suggests one further filter easy to be checked, to be installed on the

gas pipe supply.

2.3.6 - HYDRAULIC COMPENSATOR OR OPEN MANIFOLD

For the correct operation of the boiler, the use of an hydraulic compensator is advisable because it guarantees:

- separation and gathering of circuit dirt
- best air venting
- hydraulic de-coupling of the two hydraulic circulation circuits.

TABLE FOR THE RECOMMENDED DIMENSION OF THE HYDRAULIC COMPENSATOR

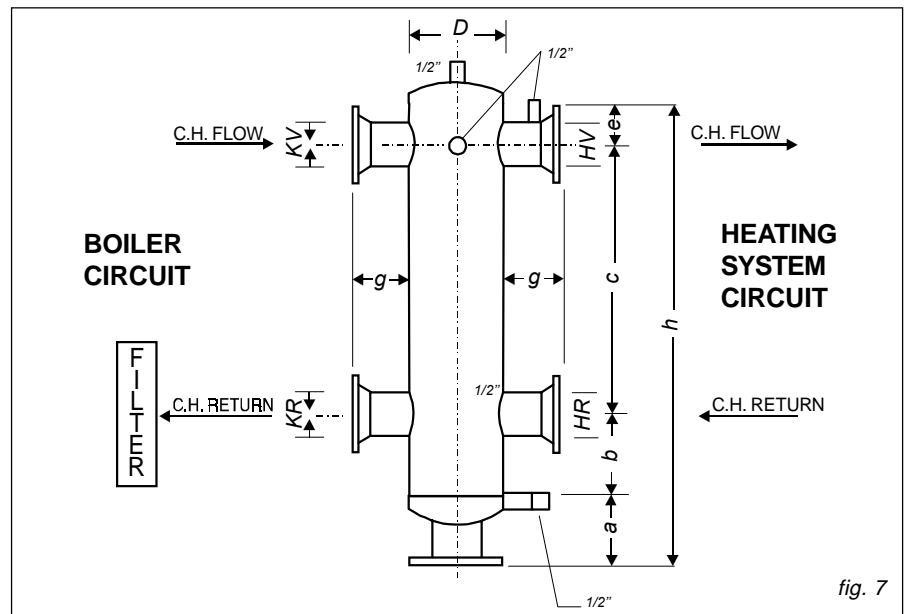

MODULEX MODEL	FLOW RATE l/h	D mm	KV DN	KR DN	HV DN	HR DN	a mm	b mm	c mm	e mm	h mm	g mm
360 kW	20.000	200	100	100	100	100	200	300	1.000	150	1.650	200
360 - 450 kW	30.000	250	125	125	125	125	200	300	1.000	150	1.650	200
450 - 540 - 630 kW	50.000	300	150	150	150	150	250	300	1.000	150	1.700	200
Over	100.000	400	200	200	200	200	250	300	1.500	200	2.250	200
> 630 kW	150.000	500	250	250	250	250	300	400	1.500	300	2.500	200
	200.000	600	300	300	300	300	300	400	1.800	300	2.800	200

2.3.7 - FILTER

UNICAL suggests the installation of a Y filter with two gate valves on the return pipe so that it can be cleaned if necessary. Such filter shall protect the boiler

from the heating system dirt. Its regular cleaning has to be foreseen.

2.3.8 - BALL VALVES

Unical suggests the installation of ball gate valves on the system flow/return pipes. In this case the boiler, if necessary, can be disconnected or drained, without having to drain the whole sys-

tem. A closed expansion vessel, properly dimensioned and equipped with its safety valve, shall be fitted between the gate valves and the boiler.

WARNING!

Never intercept safety devices, such as safety valve and expansion vessel.

2.3.9 - FEEDING WATER QUALITY

- The system and reinstatement water chemical-physical features are fundamental for the boiler correct operation and safety.
- Among the inconveniences caused by feeding water low qualities the most frequent and serious one is the scale deposit on heat exchange surfaces.
- Less frequent but not less serious is the water side corrosion of all heating circuits surfaces.
- It is known that calcareous scales reduce heat exchange due to their low heat conductivity, so that even few mm-thick scales may cause very dangerous localised overheating.

- Water treatment is advisable in the following cases:

- A) high hardness of the available water (> 20°f)
- B) very large heating systems
- C) high quantities of reinstatement water due to leakages or maintenance works
- The use of an inhibitor is advisable to treat feeding waters and to protect heating systems against calcareous scales, corrosion and microbiologic growth. In case of freezing as well, the use of an anti-frost together with the inhibitor is advisable.
- Qualified companies can provide boiler de-scaling.

- Any system needs water re-filling because of evaporation, small or substantial leakages and maintenance. It is then necessary to calculate the water quantity requested to avoid new inconveniences due to untreated water. To this purpose, the installation of a water flow-meter is advisable on reinstatement pipe.

2.3.10- BOILER ANTIFROST PROTECTION

Should the flow temperature (measured at global flow temperature NTC) decrease under 7°C, the system pump is set up. Should temperature ulteriorly

decrease (under 3°C), all modules shall start at min. output until the return temperature reaches 10°C. Such protection device is exclusively for the boiler. For

the protection of the whole system, a second anti-frost thermostat is necessary to switch on the heating system pump.

2.3.11 - MINIMUM WATER FLOW RATE

A minimum water flow rate, as shown in the table on the right, is to be guaranteed through the boiler at any time.

RECIRCULATION PUMP

The recirculation pump shall have a manometric head able to assure the water flow rate as per the diagram of fig. 8.

Pumps shall be calculated by installers or technical engineers according to boiler and system parameters.

kW output	360	450	540	630
Max water flow rate Demanded in m ³ /h ($\Delta t=10$ °C)	30,96	38,70	46,44	54,18
Max water flow rate Demanded in m ³ /h ($\Delta t=15$ °C)	20,64	25,80	30,96	36,12
Max water flow rate Demanded in m ³ /h ($\Delta t=20$ °C)	15,48	19,35	23,22	27,09

The water side resistance curve of the boiler is shown in fig. 8. The pump is not an integral part of the boiler.

It's recommended to choose a circulator with the rate and discharge head around 2/3 of its characteristic curve.

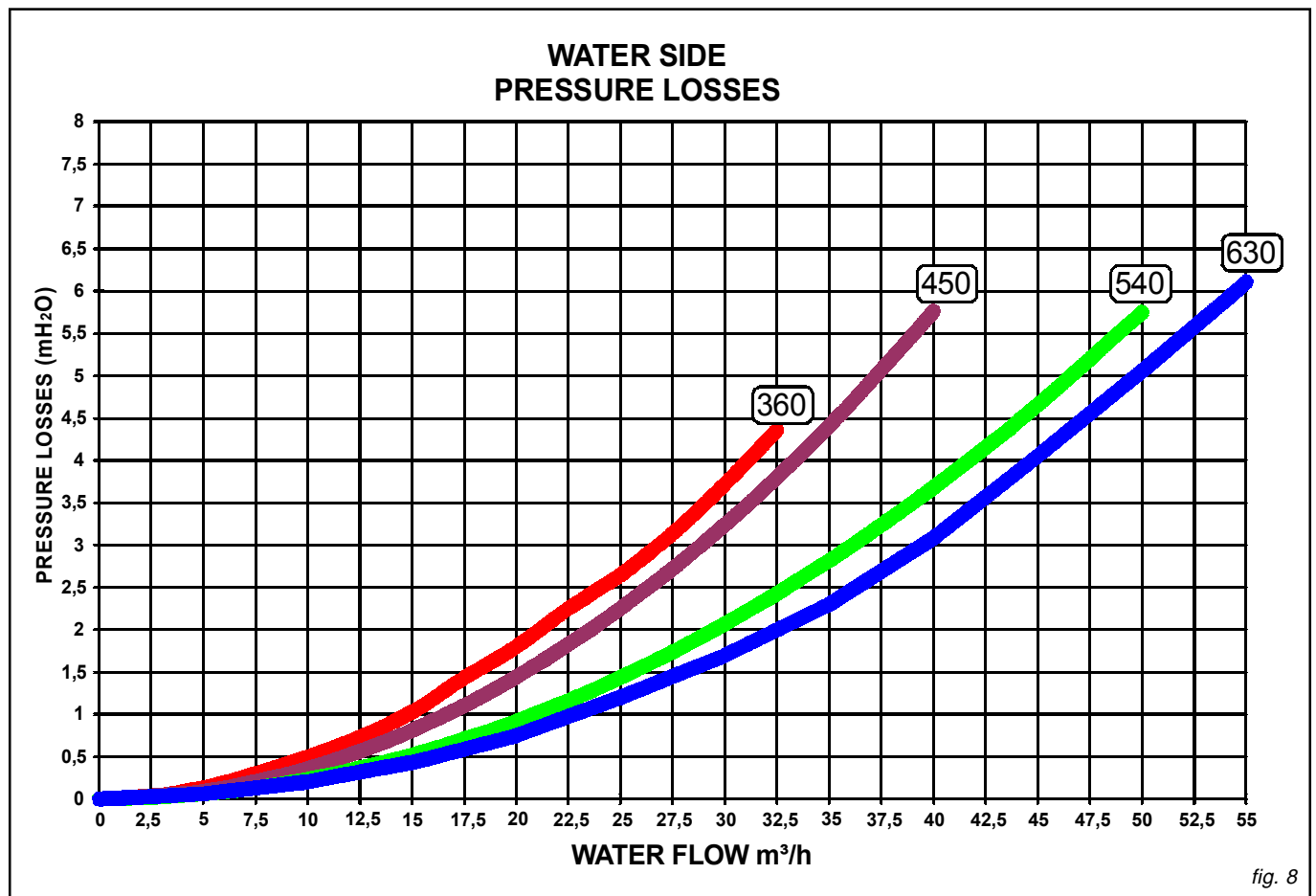

fig. 8

2.4 - BOILER OPERATION

The boiler consists of mutually connected combustion chambers; each of them has its own burner, fan with air pressure switch for control, two gas valves with ignition and ionisation device.

Each group of these components is called thermal element.

Max. output of a thermal element is 90 kW. So, a 630 kW boiler consists of 7 thermal elements.

Each thermal element has its own temperature sensor NTC - Negative Temperature Coefficient - called local NTC, which locally checks the flow tempera-

ture of each thermal element.

The flow temperature at the boiler outlet and the return temperature at the boiler inlet are controlled by global NTC temperature sensors (see fig. 2).

In case of more heat request by heating or DHW systems, the boiler starts up and water will be heated by an aluminium boiler body. Then the boiler pump sends water to the mixing bottle and from here to the radiators, according to the heating system chosen.

The combustion air is supplied by fans and taken in from the boiler room. The combustion air is then pushed into the pre-combustion chamber through a diaphragm. Beyond the diaphragm, the air

mixes with gas and such mixture passing through the non-return valve is sent to the burner. Then, on leaving the burner surface, the air/gas mixture ignites electrically and the resulting combustion gases, after being transported (and cooled) through finned tubes, enter the condensate collecting manifold and then are evacuated through the chimney.

2.4.1 - GENERAL DESCRIPTION

When there is an heat request from a room thermostat or an outer compensator, the Modular Boiler Drive (MBD) calculates the necessary output according to the difference between the set temperature (or the temperature calculated by the outer compensator) and the global flow temperature. The number of thermal elements (each thermal element represents a maximum output of 90 kW) x 100% determines the maximum output expressed in %.

When the output has been determined, the boiler pump (not supplied by Unical) is set up and the fan of one thermal element is set in motion at starting speed. The gas valve opens and ignition is to occur within 5 sec. When the ionisation electrode detects the flame, the thermal element starts operating.

Subsequently other thermal elements are likely to start in the same way. One of the operation principles for this boiler is letting as many burners as possible operate simultaneously at minimum load to reach the maximum efficiency.

For example, if a 4 thermal element boiler is requested to operate at its max output, this shall be 400% i.e. :

90 kW x 4 thermal elements = 360 kW = 400%.

If it is requested to operate at 200% output, thanks to the output sharing system on the highest number of thermal elements, each thermal element will operate at 50% output i.e. :

200% : 4 thermal elements = 50% equal to a total of 180 kW, that is 45 kW for each thermal element.

Such principle provides clearly efficiencies much higher than those obtained in traditional groups of small boilers installed in cascade.

When the output shared on each thermal element is less than 22 kW, one thermal element after the other is automatically excluded and the remaining output is shared on thermal elements having the smallest number of operation hours (by the automatic operation-time calculating system).

Modulation, i.e. output reduction, is based on the difference between the set temperature (or the temperature calculated by the outer compensator) and the global flow temperature.

When no ignition occurs, the ignition device puts to lock out position the thermal element concerned.

1 Thermal element = 90 kW = 100%

4 Thermal elem. = 90 kW x 4 = 360 kW = 400%

$$400\% : 360\text{kW} = 200\% : X$$

$$X = (200 \times 360) : 400 = 180 \text{ kW output shared on 4 thermal elements}$$

$$\text{Output shared on 4 thermal elements : total output} = 180 : 360 = 0,5 = 50\%$$

4 thermal elements of 90 kW each working at 50% of the output give = 180 kW = (200%), i.e. 45 kW / thermal element

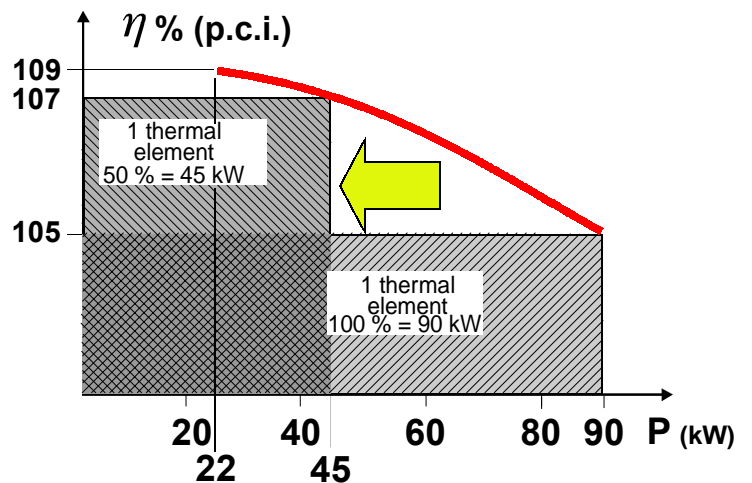
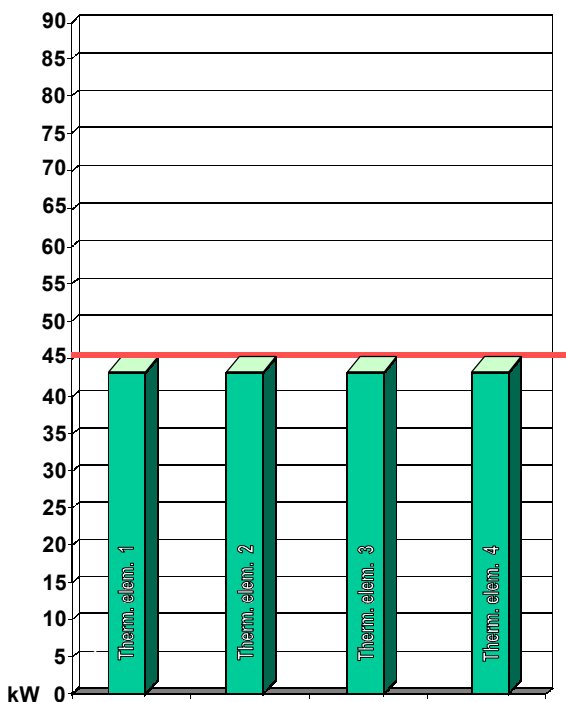

- Efficiency of a thermal element working at full capacity (90 kW) = 103 % (in condensation)
- Efficiency of a thermal element working at reduced capacity (45 kW) = 107 % (in condensation)
- Efficiency of a thermal element working at minimum capacity (22 kW) = 109 % (in condensation)

All the thermal elements work in parallel at the same output, equalizing, thus, the C.H. system efficiency to the one of the thermal element.

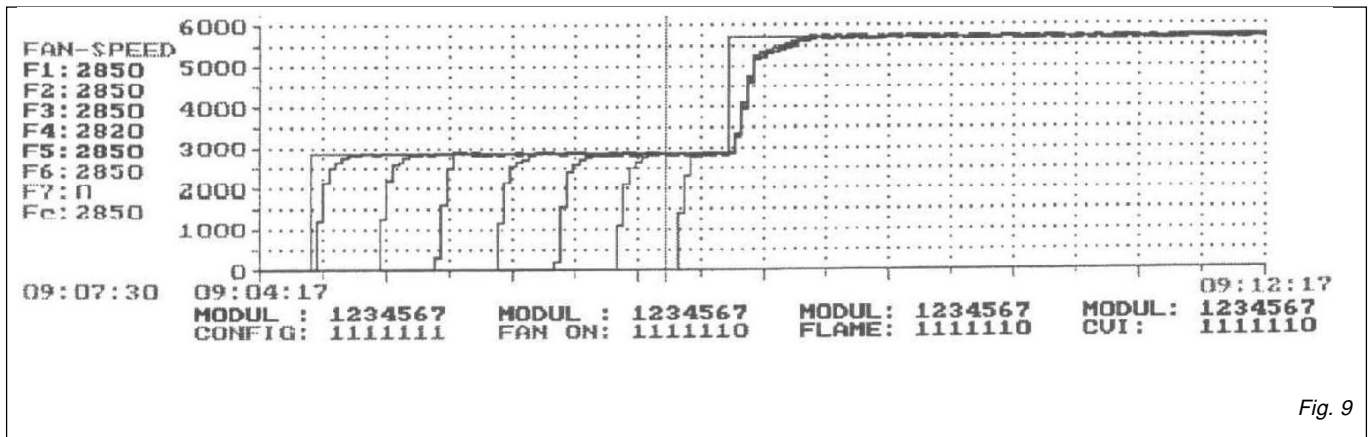

Fig. 9

Ignition diagram, for Modulex 630, with 7 burners. (6 are working, 1 is during ignition procedure).

2.4.2 IGNITION SEQUENCE

5 seconds after the switch ON-OFF is ON, the pump is set up together, eventually, with the 3-way valve in the case of a heat request from the Room Thermostat. The ignition PCB ("CVI" means Combined Valve and Ignition) is powered on and, after 24 sec, the fan is set in motion and reaches the starting speed; it stays in operation making the pre-purge of the combustion chamber for 10 sec; in the meanwhile the air pressure switch, actuated by the fan, switches from C-NO (open position) to C-NC (closed position) allowing the ignition spark to be obtained and the gas valve to be opened after 5 to 8 sec allowing the AIR/GAS mixture. If within the safety time there is no burner lighting the burner is put definitely in lockout position (the relevant red push button, on the front panel board, will light).

When heating and/or DHW request ceases, the pump stays in overrun according to relevant pre-set times. Such sequence is the same for the other burners without, necessarily, keeping the lighting se-

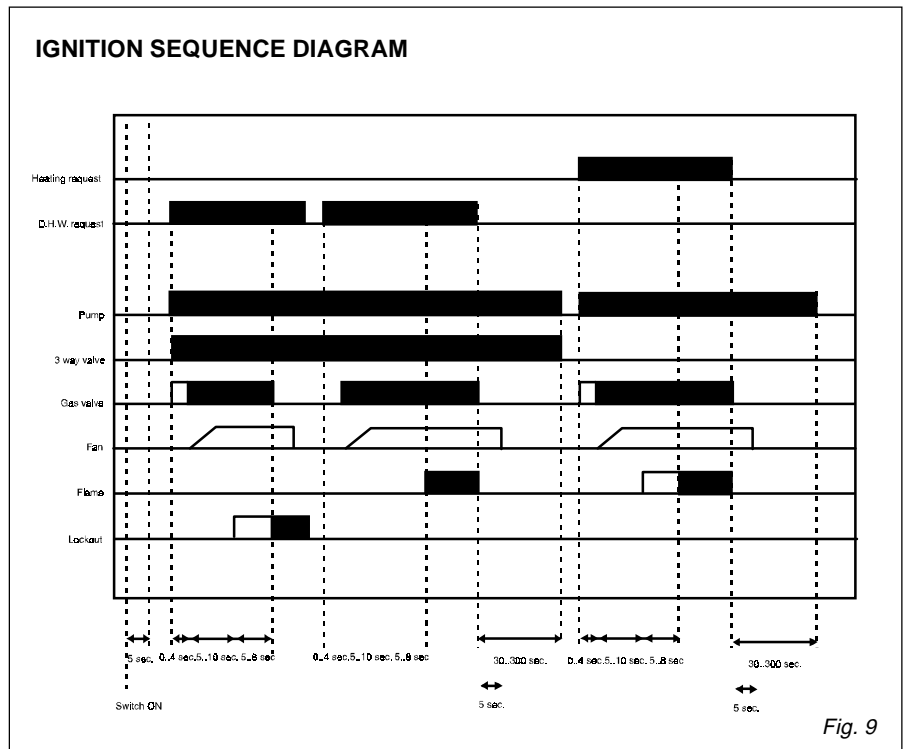

Fig. 9

quence in their assembling order, but in their operation hours.

2.4.3 - SUPPLEMENTARY BOARD

The Modular Boiler Drive (MBD) in fig. 9, supplied for each boiler by Unical, manages to check a two-burner group (2 x 90 = 180 kW). For boilers with output > 360 kW, 2 or 3 supplementary boards AM-5 are assembled by the manufacturer, each of them managing to check up to 2 burners. For example, a boiler with 5 burners (450 kW) is equipped with two supplementary boards AM-5.

The supplementary boards have two small dip-switches, which shall be positioned according to the patterns here below, regardless the number of supplementary boards AM-5 fitted (such operation is carried out at the manufacturer's workshop and will also be done on site in case of the replacement of a faulty one).

- X1 = CVI supply (ignition PCB)
- X2 = CVI supply (ignition PCB)
- X3 = 230 V electrical supply from mains
- X7 = to MDB by flat cable

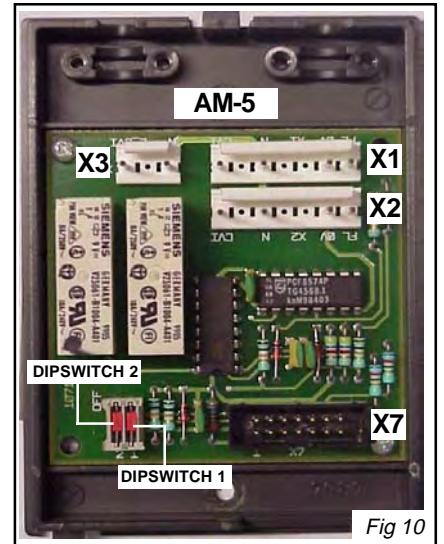
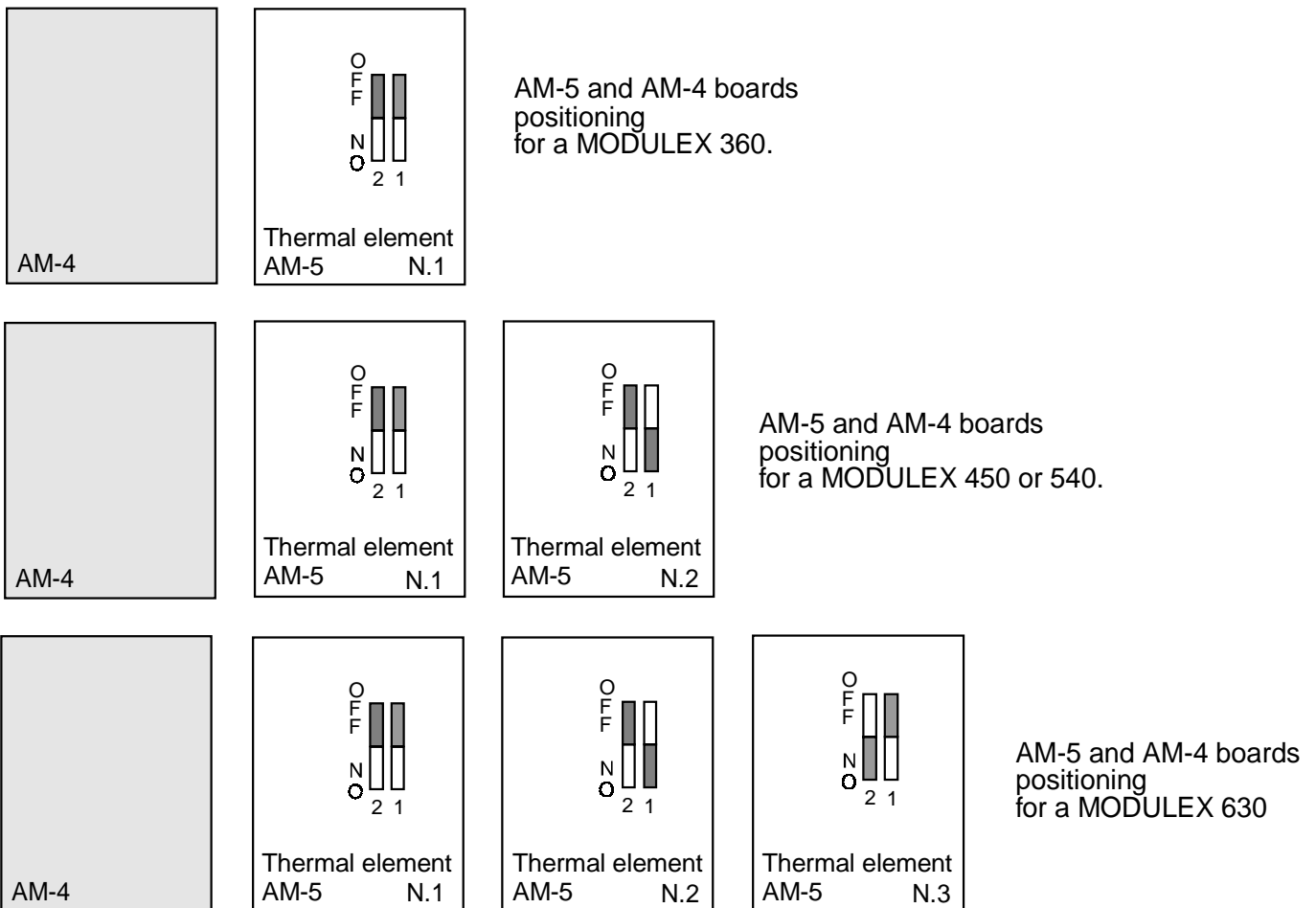

Fig. 11-
SUPPLEMENTARY BOARD.

POSITIONING OF THE DIPSWITCHES



2.4.4 - DOMESTIC HOT WATER (DHW) MODE OPERATION

Each boiler is equipped with an AM-4 board, necessary to control a D.H.W tank and to receive a 0 - 10V signal from an outer compensator (see fig. 11). If there is a heat request, the MBD can control either a storage tank loading pump or a 3-way diverting valve. So the boiler will ignite and operate according to what previously described. The global flow water temperature, set as standard 20 K higher than the requested DHW temperature, is modulated as well. By using dip-switches, it is possible to limit the boiler output when working in D.H.W mode, in order to avoid overheat when the DHW storage tank absorbed output is less than the boiler produced one. DHW production has always priority on heating. Some examples about hydraulic and electric connections of a hot water storage tank are shown in the figures 6.1 - 6.2 - 6.4 .

*For example:
If we combine a 90 kW storage tank to a Modulex 360, setting the dip-switch 1 to "OFF" and the dip-switch 2 to "OFF", so as to adjust the functioning of the number of modules on the basis of the storage tank's requests (one module will function).*

If we combine a 180 kW storage tank to a Modulex 360, setting the dip-switch 1 to "OFF" and the dip-switch 2 to "ON", two modules will function.

If we combine a 270 kW storage tank to a Modulex 360, setting the dip-switch 1 to "ON" and the dip-switch 2 to "OFF", three modules will function.

If we combine a 360 kW storage tank to a Modulex 360, setting the dip-switch 1 to "ON" and the dip-switch 2 to "ON", four modules will function.

- X1= diverting valve or storage tank loading pump
- X2= outer compensator / D.H.W. tank NTC
- X7= to the MBD by flat cable

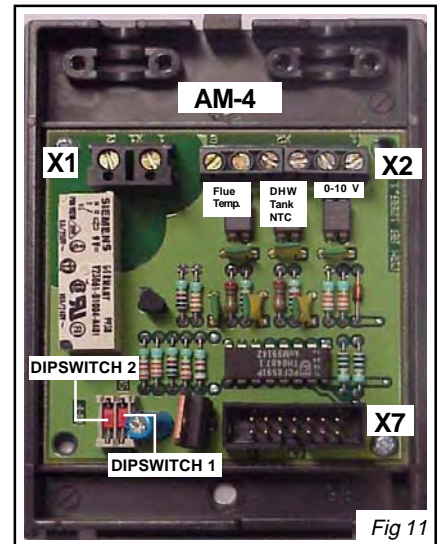

Fig 11

IN THE MODULEX BOILERS WITH AN OUTPUT HIGHER THAN 360 KW

In order to guarantee the best D.H.W. production the dip-switches present configuration allows a maximum availability up to 360 kW.

DIPSWITCH CURSOR POSITION

REGULATION	360 kW	270 kW	180 kW	90 kW
CONFIGURATION				
	Four modules are ignited (360 kW)	Three modules are ignited (270 kW)	Two modules are ignited (180 kW)	Just one module is ignited (90 kW)

2.5 - OPERATION IN CASE OF TECHNICAL INTERVENTION

For after sale service and test reasons, any single thermal element or all simultaneously can be kept operating at full or reduced load. In this way the CO₂ level

can be checked and, if necessary, adjusted at full or reduced load (for any single thermal element or for all simultaneously).

Thanks to this option the search for failures on each thermal element will result easier.

2.6 - ELECTRIC CONNECTIONS

The MODULEX electrical connections are defined in the chapter "Wiring diagram" (paragraph 2.6.1).

For electrical features see appliance data plate.

The boiler installation needs a supply of 230 V – 50 Hz – single phase, and must be workmanlike performed, as foreseen by the local and international electrical rules in force and without the utilisation of adapters, multiple sockets or extension cords. It is fundamental to check this safety requirement. If in any doubt, ask for an accurate control of your electric system by highly qualified personnel.

UNICAL is not liable for any damage caused by unproper earthing system.

The gas and water feeding pipes and the C.H. system pipes cannot be used as earthing means.

Boiler electric safety is guaranteed only when it is properly connected to an efficacious earthing system in compliance with the regulations in force.

The use of any power supplied equip-

ment implies the observance of some fundamental rules, such as:

- do not touch the boiler with any wet part of your body and/or barefooted;
- do not pull the supply cable;
- do not expose the boiler to sunlight, rain, etc...;
- keep the boiler away from untrained people.

The boiler supplying cable shall not be replaced by the user. In case of any damage to the cable, stop the boiler and contact qualified personnel for its replacement.

For the technical characteristics see the boiler data plate.

The boiler electrical supply (230 V – 50 Hz – single phase) is to be done directly on the three pole plug **A** (fig. 12) supplied with the boiler. This boiler is phase sensitive, it means that **Phase** and **Neutral** wires from mains have to be connected to **Phase** and **Neutral** terminals of the three pole plug, otherwise the boiler will go in lockout position.

It is necessary to fit a double pole switch on the supply line in an easy accessi-

ble position in order to make quick and safe the service operations.

WARNING!

230 V cables shall be separated from 24 V ones, using the two plastic conduits supplied within the boiler casing L.H. side panel.

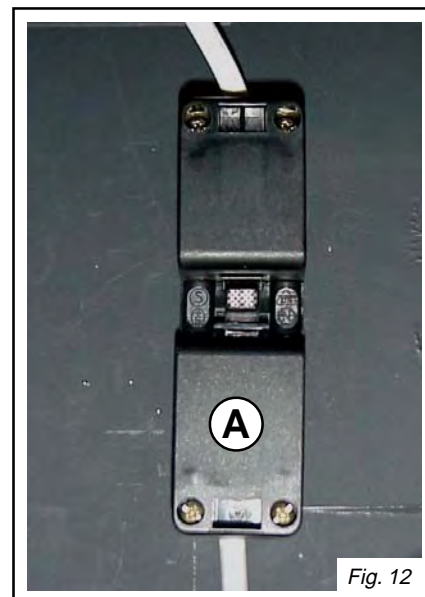

Fig. 12

TABLE OF RESISTANCE OF NTC1 - NTC2 - NTC3

Relationship between temperature (°C) and nominal resistance (Ohm) of the sensors NTC1 - NTC2 - NTC3

Example:

- At 25°C, resistance is 12000 Ohm
- At 90°C, resistance is 1300 Ohm

Temperature (°C)	resistance (Ohms)
0	35400
10	22500
20	14700
25	12000
30	9835
40	6712
50	4672
60	3311
70	2388
80	1749
90	1300
100	980
110	749

2.6.2 - WIRING CONNECTIONS OF THE IGNITION ELECTRONIC CARD

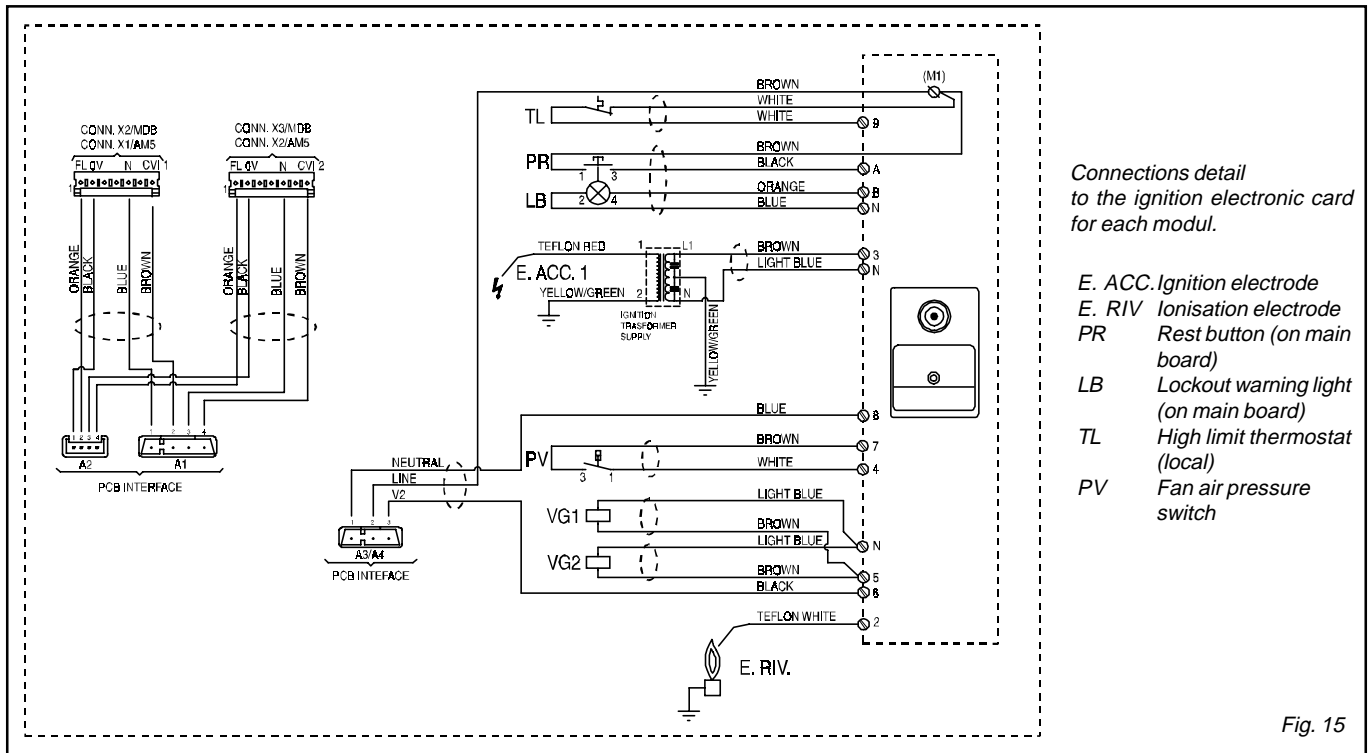

Fig. 15

2.6.3 - ELECTRICAL CONNECTION TO AN OUTER COMPENSATOR, A ROOM THERMOSTAT OR AN OUTER TEMPERATURE SENSOR

Outer compensator: connect the compensator 0-10V outlet signal to terminals 9 - 10 of the 20-pole terminal-strip (see fig. 16). By using this signal it is possible to set a global flow temperature depending on the outdoor temperature.

ON/OFF room thermostat or programmer: it shall be connected to the terminals 5-6 of the 20-pole terminal-strip (see

fig. 16).

Outdoor sensor: supplied as standard, it must be fitted on an outer wall exposed to North or North-East, at a minimum height from floor of 2.5 m. The mounting in proximity of opening windows and doors and ventilation grates has to be avoided. Never fit the outdoor sensor in a sunny position. It shall be connected to terminals 3 - 4 of the 20-pole terminal-strip (see fig. 16).

To avoid electromagnetic disturbances it is necessary to separate the external sensor wiring (between sensor and terminal strip) from the 230 or 400 V harness (a plastic conduit

for 230 or 400 V harness and one for 24 V wiring)

Depending on the outdoor temperature detected by the sensor the boiler will modulate and adjust the flow temperature according to the programmed heating curve (see fig. 19).

ON/OFF room thermostat in combination with outdoor sensor: When both devices are connected as shown here below, the boiler will modulate and adjust the flow temperature according to the room and outdoor temperature detected by the two sensors (see fig. 19).

Note. The terminals 11 – 13 and 16 – 18 must be used to control a 3-way valve or a DHW tank loading pump or a boiler pump through relays, as shown in the hydraulic schemas of fig. 6.1 to fig. 6.6. NEVER supply directly from these terminals the a.m. devices .

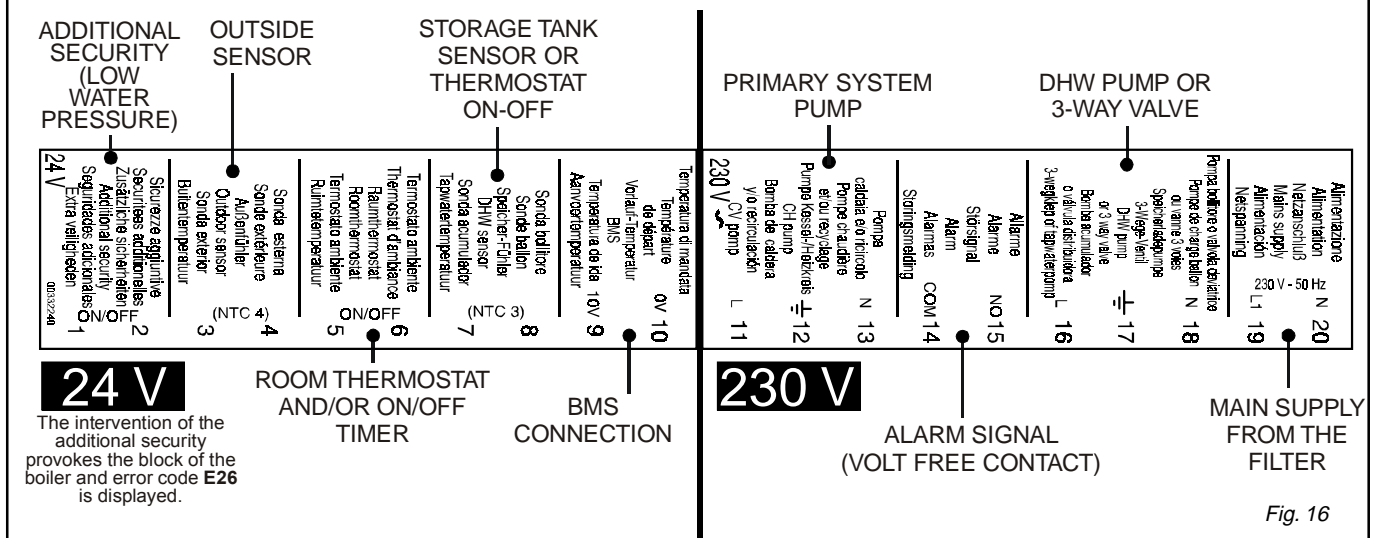
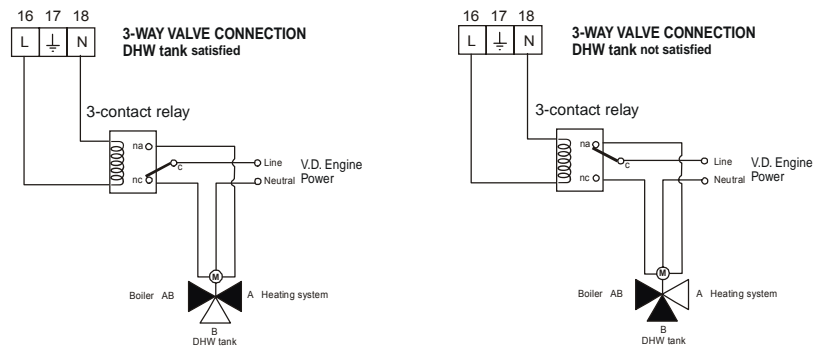

Fig. 16

2.6.4 - DHW STORAGE TANK

DHW production by an outer storage tank connected to the boiler can be carried out by an electric diverting valve or a separated storage tank loading pump. Both devices can be chosen via the control panel push buttons, by selecting the right parameter A (see paragraph 3.2.8.2, parameter A - 2nd digit). The DHW tank NTC sensor, supplied as an option, will be connected to the terminals 7 – 8 of the 20-pole terminal-strip.

ELECTRICAL CONNECTION OF THE THREE WAY VALVE



WARNING!

There is a 230 V tension between terminals 16 - 18 only when there is a heat demand by the DHW NTC sensor or by a DHW thermostat; in this case the display will show : 4 XX (see 3.2.5).

ELECTRICAL CONNECTION OF A DHW TANK LOADING PUMP

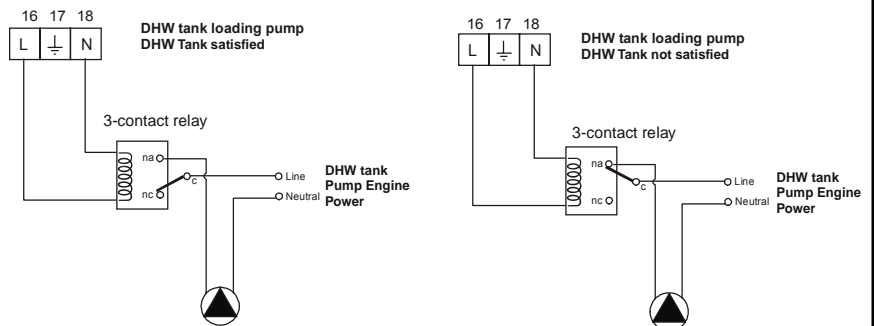

WARNING!

There is a 230 V tension between terminals 16 - 18 only when there is a heat demand by the DHW NTC sensor or by a DHW thermostat; in this case the display will show : 4 XX (see 3.2.5).

ELECTRICAL CONNECTION OF A BOILER PUMP (OR A DHW LOADING PUMP IF WITH A 3-WAY VALVE) Boiler pump or DHW loading pump

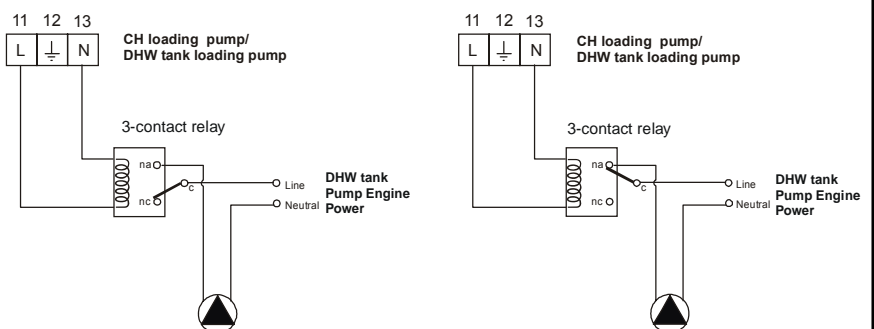

WARNING!

There is a 230 V tension between terminals 11 - 13 only when there is a heat demand by the DHW NTC sensor or by a DHW thermostat; in this case the display will show : 4 XX (see 3.2.5).

Fig. 17

3

OPERATION OF THE MAIN PCB, NAMED MBD (MODULAR BOILER DRIVE)

3.1 - GENERAL DESCRIPTION

The Standby mode is on 5 sec. after starting or resetting the boiler. Subsequently the pump is set up for 1 min. If no heat is requested, this procedure is

performed every 24h (automatic anti-jamming system for boiler pump or re-circulation pump). If a DHW production boiler does not use a 3-way valve but rather a

storage tank loading pump, such a pump is set up for 1 min every 24h if no heat is requested. In this way the pump will not jam.

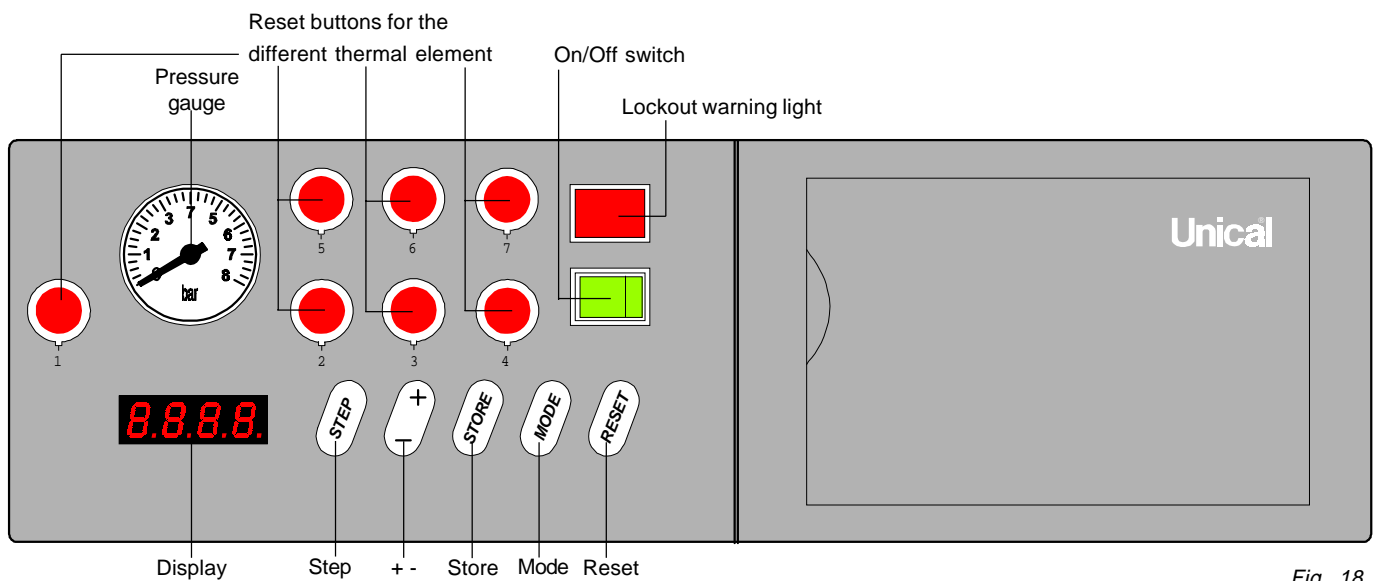

Fig. 18

Operation and indications on the display (example with 7 thermal elements)

3.2 - OPERATION AND DISPLAY INSTRUCTIONS

The control panel has 5 function keys, **STEP - +/- -STORE - MODE - RESET**, one display, one ON/OFF main switch, 2 to 7 reset buttons with lockout warning light and one pressure gauge. All different operation modes are displayed by slightly pressing the **mode** key.

If no other keys are pressed within 15 minutes from the last pressing, except when the **TEST** mode is used, the panel board will go into **standby** mode displaying the *global flow temperature*. **Standby** mode gives information as shown in par. 3.2.6 concerning the MODULEX instantaneous operation phase.

3.2.1 - "MODE" KEY

The default set mode of the boiler is **stand-by** mode. By this mode, the 4-digit (letters or figures) display shows the flow temperature or the operation state (from 0 to 9 – see par. 3.2.7).

The indication on the display will be:

X XX, where the 1st digit indicates the number of step (operation state - see par. 3.2.7) while the 3rd and 4th ones the flow temperature value.

By slightly pressing the **mode** key, **PAR** (abbreviation for *parameter*), which is one of the 6 operation modes (main menu), is displayed.

By slightly pressing the **mode** key again, the 4-digit display will show **0000**.

After entering the access code, strictly reserved to the installer and the service technicians, it is possible to go into the extended programming menu and into the following modes:

EEEL and **HOUR**

By slightly pressing the **mode** key again, the 4-digit display will show **EEEL**.

In this mode it is possible, only by the installer or service technician, to make the fine adjustment of the combustion for the complete boiler or for each single thermal element at high or low output (see par. 3.2.10), acting on the CO₂ level.

By slightly pressing the **mode** key again, the 4-digit display will show **HOUR**.

In this mode it is possible to check, only by the installer or service technician, the operation time for each burner. It is also possible to calculate the total operation time of the boiler.

3.2.2 - "STEP" KEY

Once one mode, among the four modes mentioned above (i.e. **para – data – test – hour**), has been selected by pressing **mode** key, it is possible to choose, by pressing **step** key, the parameter and

the thermal element (or the whole boiler) whose values have to be changed or to be checked.

3.2.3 - "+ / -" KEY

Once the values requested have been entered, it is necessary to store them in order to make them operative. To this purpose, press **store**.

3.2.4 - "STORE" KEY

Once the values requested have been entered, it is necessary to store them in order to make them operative. To this purpose, press **store**.

In the par. 3.2.6 is shown the procedure how to get into the extended programming menu.

3.2.5 - SERVICE CODE

The access to some programming parameters is reserved only to service technicians and, if necessary, to the installer. This access is protected by a secret service code.

To enter this code proceed in the fol-

lowing way:

Keep **mode** and **step** keys pressed simultaneously: **C.XX** (a random code) is displayed.

By using the "+/-" key, replace this code with the secret one and, always keep-

ing **mode** and **step** keys pressed, press **store**. When the right code has flashed once, it has been stored.

After entering the service code, the display reverts to **stand-by** mode.

3.2.6 - Continuous

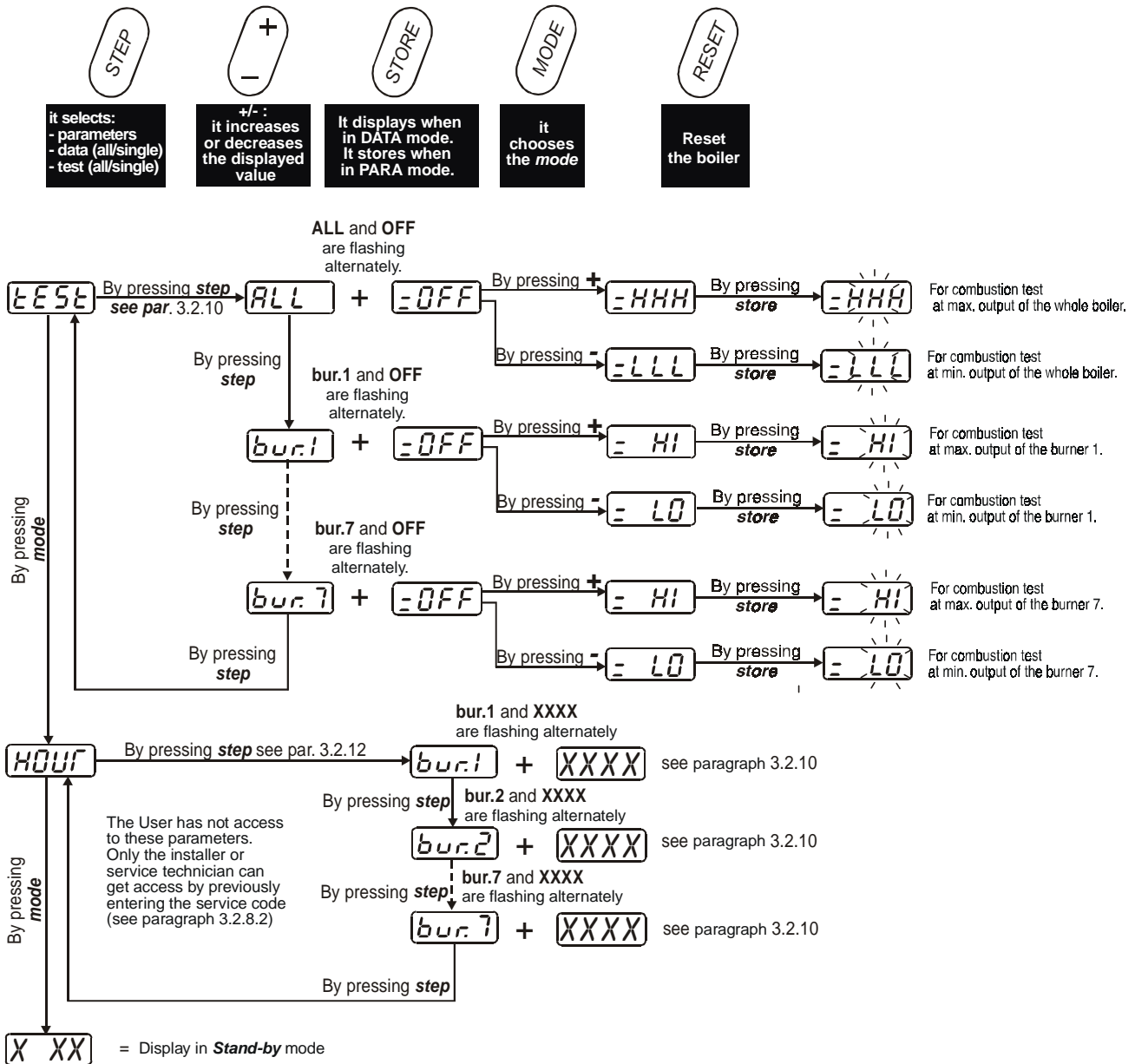

After the 1st burner has been adjusted, push **step** in order to control the next burner and switch it on.
 Before the new burner adjusting it's necessary to switch-off the previous one. Do it by pushing as much time as necessary the button **step** up to visualize the burner already adjusted: set it **OFF**.
 Only now it will be possible to do the smoke combustion analysis of the new burner.
 From 1°C more than parameter 4 value, up to 60°C

3.2.7 - STAND-BY MODE

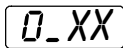

The first digit indicates the number of the step in which the boiler is; e.g. 0. In this case the last two digits will indicate

the water flow temperature. Should the first digit be 4, the last two digits would indicate the loading temperature of the heat exchanger of DHW tank. For the steps 1 - 2 and 5 the thermal

element starting steps are displayed instead of the flow temperature. The following table is a list of all the different program steps with the relevant description on the right.

Step No.	Description
0 =	standby: no heat request
1 =	the fan of the thermal element shown on the display reaches the starting speed
2 =	the safety time of the thermal elements shown on the display elapsed without any problem
3 =	the boiler is running to supply the heat requested by the heating system
4 =	the boiler is running to fulfil the DHW production request
5 =	the thermal element shown on the display is in pre-purging
6 =	the burner is stopped on request of a control device
7 =	the post-circulation after a C.H. system heat request is active
8 =	the post-circulation after a DHW storage tank heat request is active
9 =	complete switch Off, usually with an "E" error number or with burner off during the DHW preparation

List of the steps and the relevant functions the boiler is carrying out.

3.2.8 - PARA MODE

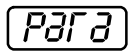

When in *stand-by*, press the **mode** key and **Para** is displayed.

3.2.8.1 - OPERATION PARAMETERS PROGRAMMABLE BY INSTALLER AND USER

Para-meters	Description	Possible Adjustment	Factory adjustemnt	Adjustment range
1	Requested DHW Temperature in the storage tank	40-65 °C	60	40-65 °C
2	C.H. and D.H.W. production ON or OFF options	00 = DHW production and Heating are both OFF 01 = DHW production is OFF and Heating is ON (boiler pump stops: only makes post-circulation according parameter 9) 02 = DHW production is OFF and Heating is ON (boiler pump is always running) 11 = DHW production and Heating are both ON (boiler pump stops; only makes post-circulation according parameter 9) 12 = DHW production and Heating are both ON (boiler pump is always running)	01	00,01,02,11,12
3	Global Flow Temperature Regulation	30-90 °C	80	30-90°C

**3.2.8.2 - OPERATION PARAMETERS PROGRAMMABLE ONLY BY INSTALLER AFTER ENTERING THE SERVICE CODE
(Available at UNICAL Service)**

Parameters	Description	Adjustment range
4	Min. global flow temperature adjustment, for outer temperature of 20° when using the heating curve (see fig. 19)	15 to 60°C
5	Min. outer temperature used in the calculation of the C.H. system, when using the heating curve (see fig. 19)	-20 to 10°C
6	Heating stop temperature when the value calculated by the outer NTC sensor is lower than the pre-set temperature	Da 1 K > t° di regolazione del parametro 4 fino a 60°
7	This parameter for night shift of flow temperature (see fig. 19) is use only when programmer is fitted. When the 1 st digit of the parameter A (see below) is 1 the reduction is active.	0 to 40 K
8	1st digit: adjustment of the outer temperature read by the outer sensor 2nd digit: C.H. hysteresis, i. e. the temperature difference against the set temperature to which the boiler should restart. By the way it is convenient to consider that the switching off temperature is always 5K above the set point	-5 to 5 K 0 to 9 K
9	Post-circulation time of boiler pump in C.H. mode	3 to 99 min
A	Two digit parameter: is used to make the configuration of Heating system and DHW production If heating system is controlled by: - ON/OFF room thermostat or programmer - outer sensor (based on parameter 6 - see paragraph 3.3.2); if the programmer is fitted the night shift of flow temperature is active - outer compensator with 0 - 10 V outlet, where 0 V corresponds to the minimum flow temperature and 10 V to the maximum temperature If D.H.W. production is controlled by: - Storage tank loading pump , (downstream the mixing bottle) or 3 way valve normally open towards C.H. system (upstream the mixing bottle) - Storage tank loading pump (upstream the mixing bottle) - Reversed 3 way valve (normally open towards DHW tank)	1st digit = 0x (*) 1st digit = 1x (*) 1st digit = 2x (*) 2nd digit = x0 2nd digit = x1 (solution not used) 2nd digit = x2
B	Differential temperature rise which increases the boiler flow temperature during the DHW request (increase of parameter 1) in order to fulfil the request regardless the heating set temperature (parameter 3)	5 to 25 K
C	Maximum fan speed in C.H. mode operation (x 100) (<i>factory set 58</i>)	10 to 60 rpm
D	Maximum fan speed in DHW mode operation (x 100) (<i>factory set 58</i>)	10 to 60 rpm
E	Minimum fan speed (x 100) (<i>factory set 22</i>)	10 to 60 rpm
F	Starting speed, in percentage of the maximum speed, shown on the parameter C (increasable when flue discharge is difficult) (<i>factory set 75</i>)	10 to 100% Do not regulate under 50%
G	Flow temperature adjustment to 0 V when using an outer compensator	0 to 50 °C
H	Flow temperature adjustment to 10 V when using an outer compensator	50 to 90 °C
J	Combined Parameter : (two digits) Alarm: - the alarm switch is closed when the 1 to 7 modules are in lockout position (see note 1). Pump post-circulation time or 3-way valve commutation delay after D.H.W. has reached the set point temperature - adjustable by 30 sec steps up to (9 x 30 sec =) 270 sec	1st digit = 1x to 7x (see note 1) 2nd digit = x0 to x9 (x 30 sec.)
L	Hysteresis (difference between the switching ON and switching OFF boiler temperatures during the DHW production) (see Note 2)	5 to 14 K
N	Type of burner control and number of thermal elements 1 st digit of the parameter 2 nd digit of the parameter	3x = Unical standard regulation x1-x7 = No. of boiler burners

(*) Should the outer sensor (terminals 3-4) and the ON-OFF room thermostat or a timer (terminals 5-6) be connected, on opening the thermostat or the timer (terminals 5-6) with parameter A in 0x, the boiler will be switched off; on the contrary with parameter A in 1x the boiler will switch to night shift mode. If a link connects the terminal 5 to the terminal 6, the boiler will not switch to night shift mode.

NOTE 1: By entering a figure from 1 to 7 it is possible to determine the number of faulty burner from which a lockout warning signal (alarm) is desired.

NOTE 2: Should the DHW recirculation be used, the parameter L reduces the number of ignitions if the hysteresis value is high.

3.2.9 - DATA MODE

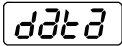

Data mode gathers a set of data about

the operation state of the boiler and of each thermal element. By using the **step** key it is possible to scroll all values. The table here below shows the data con-

tents concerning the whole boiler. When entering the service code, all other data (from 1 to 7 burners) are also programmable.

3.2.9.1 - OPERATION PARAMETERS ACCESSIBLE TO INSTALLER AND USER

Data series	Data ref.	Signification	Unit
Data relevant to the whole boiler	1	Global flow temperature	°C
	2	Global return temperature	°C
	3	DHW temperature	°C
	4	Outer temperature	°C
	5	Smoke temperature (not implemented)	°C
	6	Flow temperature adjustment	°C
	7 *	Fan speed adjustment	rpm xxxx
	8	Output calculated in % (on the complete boiler)	% xxxx

3.2.9.2 - PARAMETERS ACCESSIBLE ONLY TO THE INSTALLER BY PREVIOUSLY ENTERING THE SERVICE CODE

Data series	Data ref.	Signification	Unit
Data relevant to bur.1	1	Local flow temperature, NTC1	°C
	2	Local flow temperature, NTC2	°C
	3*	Thermal element 1 fan speed adjustment 1	rpm xxxx
	4*	Thermal element 1 actual fan speed 1	rpm xxxx
Data relevant to bur.2	1	Local flow temperature, NTC2	°C
	2	Local flow temperature, NTC3	°C
	3*	Thermal element 1 fan speed adjustment 2	rpm xxxx
	4*	Thermal element 1 actual fan speed 2	rpm xxxx
Data relevant to bur.3	1	Local flow temperature, NTC3	°C
	2	Local flow temperature, NTC4	°C
	3*	Thermal element 1 fan speed adjustment 3	giri/min xxxx
	4*	Thermal element 1 actual fan speed 3	giri/min xxxx
Data relevant to bur.4	1	Local flow temperature, NTC4	°C
	2	Local flow temperature, NTC5	°C
	3*	Thermal element 1 fan speed adjustment 4	rpm xxxx
	4*	Thermal element 1 actual fan speed 4	rpm xxxx
Data relevant to bur.5	1	Local flow temperature, NTC5	°C
	2	Local flow temperature, NTC6	°C
	3*	Thermal element 1 fan speed adjustment 5	rpm xxxx
	4*	Thermal element 1 actual fan speed 5	rpm xxxx
Data relevant to bur.6	1	Local flow temperature, NTC6	°C
	2	Local flow temperature, NTC7	°C
	3*	Thermal element 1 fan speed adjustment 6	rpm xxxx
	4*	Thermal element 1 actual fan speed 6	rpm xxxx
Data relevant to bur.7	1	Local flow temperature, NTC7	°C
	2	Local flow temperature, NTC8	°C
	3*	Thermal element 1 fan speed adjustment 7	rpm xxxx
	4*	Thermal element 1 actual fan speed 7	rpm xxxx

* Note: The parameter figure is not displayed

3.2.10 - TEST MODE

TEST

Test mode can be used for service purposes, so that each single burner can operate individually.

This mode is be used even when adjusting CO₂ % for each single burner (see par. 3.5).

Test mode is accessible only after entering the service code.

The following table is a general list of all **test** modes.

The burner No. and its operation state (OFF, HI and LO) alternatively flash on the screen.

By choosing the status OFF, HI or LO by the +/- key and pressing successively

store, it is possible to store the choice and make it operative.

Step	Option	Signification
ALL	= OFF	All thermal elements are OFF
	= HHH	All thermal elements start at high output
	= LLL	All thermal elements start at low output
bur. 1	= OFF	Thermal element 1 is OFF
	= HI	Thermal element 1 starts at high output
	= LO	Thermal element 1 starts at low output
bur. 2	= OFF	Thermal element 2 is OFF
	= HI	Thermal element 2 starts at high output
	= LO	Thermal element 2 starts at low output
bur. 3	= OFF	Thermal element 3 is OFF
	= HI	Thermal element 3 starts at high output
	= LO	Thermal element 3 starts at low output
bur. 4	= OFF	Thermal element 4 is OFF
	= HI	Thermal element 4 starts at high output
	= LO	Thermal element 4 starts at low output
bur. 5	= OFF	Thermal element 5 is OFF
	= HI	Thermal element 5 starts at high output
	= LO	Thermal element 5 starts at low output
bur. 6	= OFF	Thermal element 6 is OFF
	= HI	Thermal element 6 starts at high output
	= LO	Thermal element 6 starts at low output
bur. 7	= OFF	Thermal element 7 is OFF
	= HI	Thermal element 7 starts at high output
	= LO	Thermal element 7 starts at low output

3.2.11 - HOUR MODE

HOUR

This mode, which is accessible only after entering the service code, shows the operation time for each thermal element.

Select by the **step** key the burner whose operation time is wanted to be known. The burner No., as well as the number of operation hours, alternatively flash on the display.

Display	Operation time range	Multiplication coefficient
x.xxx	From 0.000 to 9.999 hours	Multiply the figures before comma by 1000 and the figures after comma by 1
xx.xx	From 10.00 to 99.99 hours	Multiply the figures before comma by 1000 and the figures after comma by 10
xxx.x	From 100.0 to 999.9 hours	Multiply the figures before comma by 1000 and the figures after comma by 100

Eg.

The figure 33.45 means the thermal element operation time is (33x1000 = 33,000) + (45x10 = 450) = 33,450 h, equal to about 4-year continuous operation.

3.3 - HEATING MODE OPERATION

The boiler can fulfil different requests for more heat by parameter A. When leaving the workshop, the boiler

has its parameter A set to 01 by default. Its verification is however advisable at boiler commissioning.

3.3.1 - HEATING MODE OPERATION BY ROOM THERMOSTAT

By giving the 1st figure of the parameter A the value 0 (e.g. A-0x) it means that the request for more heat is driven by a room thermostat. A simple thermostat ON/OFF can be used as room thermostat.

The setting of the flow (modulated) temperature can be done by Parameter 3. A communicating room thermostat can also be used as remote control panel. To this purpose Unical offers an interface board, which will allow the boiler and the room thermostat to communicate.

temperature exceeds by 5K the pre-set flow temperature value (i.e. Parameter 3). The boiler will start again as soon as the flow temperature has gone under the pre-set value (Parameter 3) minus the heating system hysteresis (Parameter 8).

The boiler will switch off, if the flow

3.3.2 - HEATING MODE OPERATION BY OUTDOOR SENSOR

By giving the 1st figure of the parameter A the value 1 (e.g. A-1x) it means that the request for more heat is driven by an outer sensor. When the outer sensor, which is normally supplied as standard, is installed, a heating curve is to be determined.

The flow temperature will be calculated in accordance with the detected outer temperature.

The boiler will begin modulating according to this flow temperature. When a heating curve is set, the parameters on the right are very important.

The boiler will switch off, if the flow temperature exceeds by 5K the pre-set flow temperature value (i.e. Parameter 3). The boiler will start again as soon as the flow temperature has gone under the pre-set value (Parameter 3) minus the heating system hysteresis (Parameter 8).

Parameter 3:	Maximum global flow temperature setting at the minimum outer temperature
Parameter 4:	Minimum global flow temperature setting at the outdoor temperature of 20°C
Parameter 5:	Minimum outdoor temperature
Parameter 6:	Temperature block upon request for heat. If, according to the outdoor temperature, the flow temperature value is lower than the parameter 6, there will be no heat request. This parameter can be used in summer: when the outer temperature is high, a 25°C regulation can be calculated whereas the parameter 6 can be set to 30°C. In this case the request for heat will be stopped, preventing the radiators from overheating.
Parameter 7:	The open contact of a room thermostat makes temperature decrease during the night (night shift) - see note (*) on paragraph 3.2.8.2). The night temperature decrease can be set to 0 - 40K by the parameter 7.
Parameter 8:	If it should be necessary to make a slight adjustment of the measured outer temperature because, for instance, the outer sensor NTC calibration tolerance is too high, it is possible to make an adjustment of ± 5K on the measured value, by the parameter 8.

Parameters to set by outdoor sensor.

The diagram beside is referring to the next example:

- Global flow temperature = 90°C (param. 3)**
- Minimum global flow temperature = 15°C (param 4)**
- Minimum outer temperature = -20°C (param. 5)**
- Night shift = 10°C (param 7).**

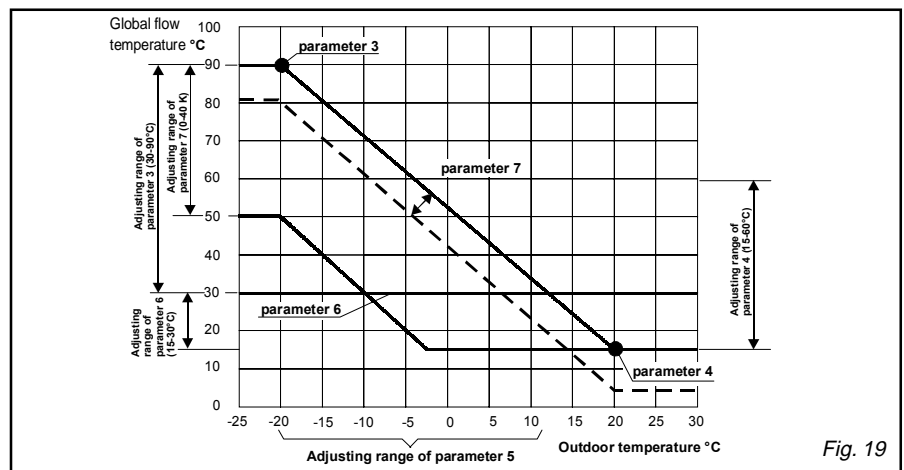

Fig. 19

Heating Curve Parameters

3.3.3 - HEATING MODE OPERATION BY OUTER COMPENSATOR (0 – 10 V signal)

By giving the 1st figure of the parameter **A** the value **2** (e.g. **A-2x**) it means that the request for more heat is driven by an outer compensator.

When an outer compensator with 0 – 10 V outlet signal is employed, this signal can be combined with the boiler. By the AM-4 PCB, the outer compensator can be combined with the boiler. The connection can be carried out on the terminal-strip of fig. 16 (terminals 1-2).

The parameters applied are shown on the right.

The boiler will switch off, if the flow

Parameter G:	the setting is carried out at a 0 V signal, equivalent to the minimum global flow temperature (parameter 4)
Parameter H:	the setting is carried out at a 10 V signal, equivalent to the minimum outer temperature (parameter 3)
Parameter 6:	Temperature block upon heat request. According to the outer temperature there will be no request for heat if the calculated setting point for the flow temperature is lower than the parameter 6. This parameter can be used in summer: when the outer temperature is high, a 25°C regulation can be calculated where as the parameter 6 can be set to 30°C. In this case the request for heat will be stopped, preventing the radiators from overheating.

temperature exceeds by 5K the pre-set flow temperature value (i.e. Parameter 3). The boiler will start again as soon as the flow temperature has

gone under the pre-set value (Parameter 3) minus the heating system hysteresis (Parameter 8).

Note: outdoor sensor and 0 - 10V outer compensator cannot be connected simultaneously.

3.4 - DOMESTIC HOT WATER (DHW) MODE OPERATION

The boiler DHW mode operation is got

through the special AM-4 PCB, supplied as standard in the panel board.

This PCB can work together with a normal thermostat or a NTC sensor controlling the storage DHW tank and an storage tank loading pump or a 3-way

valve.

The DHW mode operation takes priority on the heating system.

The terminals to be used are shown in fig. 16. As for possible configurations see fig. 17.

3.4.1 - DHW CONTROLLED BY A NTC SENSOR ON DHW STORAGE TANK

The storage tank NTC sensor, available at UNICAL's, is connected to terminals 7-8 (fig. 16). For the electrical connection of the storage tank loading pump or diverting valve see examples in fig. 6.1 – 6.6 and wiring diagrams of fig. 17.

Priority system wiring:

From the terminal-strip of fig. 16 it is possible to use a 230 V signal to activate the storage tank loading pump or the diverting valve. To connect a motorised 3-way diverting valve, refer to the wiring diagrams at par. 2.6.4. It is advisable to use the activation

Parameter 1:	Storage tank hot water set temperature
Parameter 2:	DHW Production ON
Parameter b:	Flow temperature increase : the boiler water modulated temperature is equal to parameter 1 + parameter b .
Parameter J:	Storage tank loading pump post-circulation (max. 270 sec)
Parameter L:	hysteresis between 5 and 14 °C.

The following beside parameters are fundamental for the DHW mode operation.

signal to supply the storage tank loading pump through a relay. For its electrical connections and programming, refer to figs 6.1 – 6.2 – 6.4 - 6.8 and 17.

The DHW mode operation is requested when the storage tank water temperature goes under the pre-set DHW tem-

perature value (Parameter 1) plus the pre-set hysteresis (Parameter L). The boiler will begin modulating at the temperature equal to Parameter 1 plus Parameter b. The DHW mode operation will stop when the storage tank water temperature exceeds by 5K the pre-set temperature of Parameter 1.

3.4.2 - DHW CONTROLLED BY STORAGE TANK THERMOSTAT

The conditions mentioned at par. 3.4.1 above can be applied for this type of operation as well, provided that the DHW request results from the closing

of the hot water thermostat contact (connected to terminals 7 - 8 of fig. 16 to its sensor inside a proper storage tank sheath).

In this case the parameter 1 value is to be higher than or equal to the pre-set

DHW thermostat temperature. This is necessary to ensure that the boiler begins modulating at the correct flow temperature.

Check all other parameters.

3.5 - BUNER PRESSURE ADJUSTMENT

Unscrew the sampling point cap.
Insert the analyser sensor into the sampling point and adjust the burner to test to low flame operation (test mode). Read the percentage of CO₂, which must be between 8,9 and 9,2%. If its value is not included between these values, adjust it by using the adjusting screw A (see fig. 20) you can get after removing by an ALLEN wrench the screw cap on the gas valve. By turning it clockwise, the CO₂ percentage increases, while it decreases anticlockwise. Follow the same procedure to adjust the other burners. If the CO₂ percentage is too low, check if the air and smoke ducts are not obstructed. If they are not obstructed, check if the burner and/or the exchanger (aluminium sections) are well cleaned.

WARNING!

The burner can be adjusted only when operating at low flame.

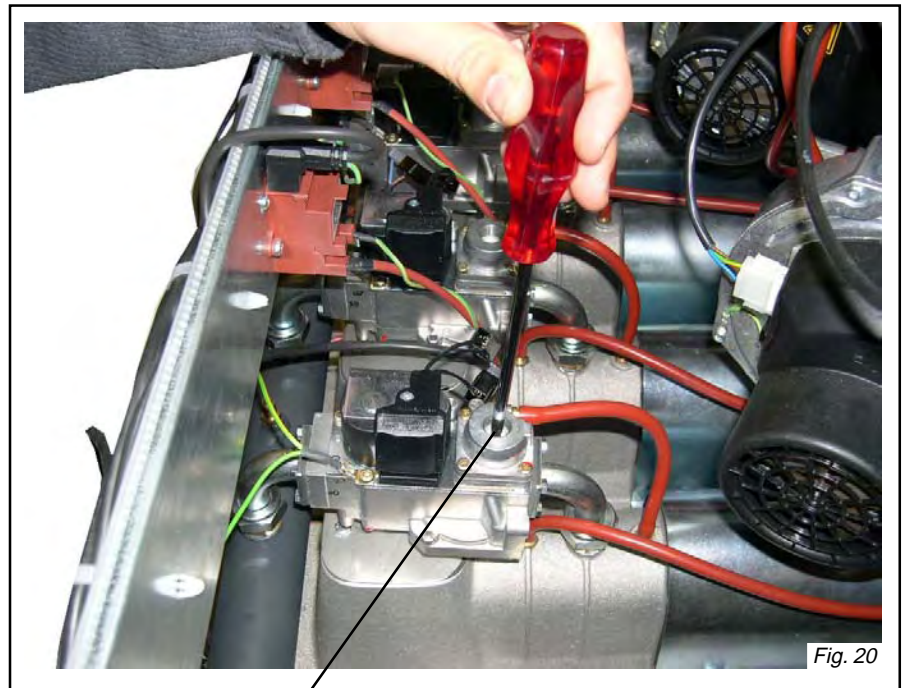
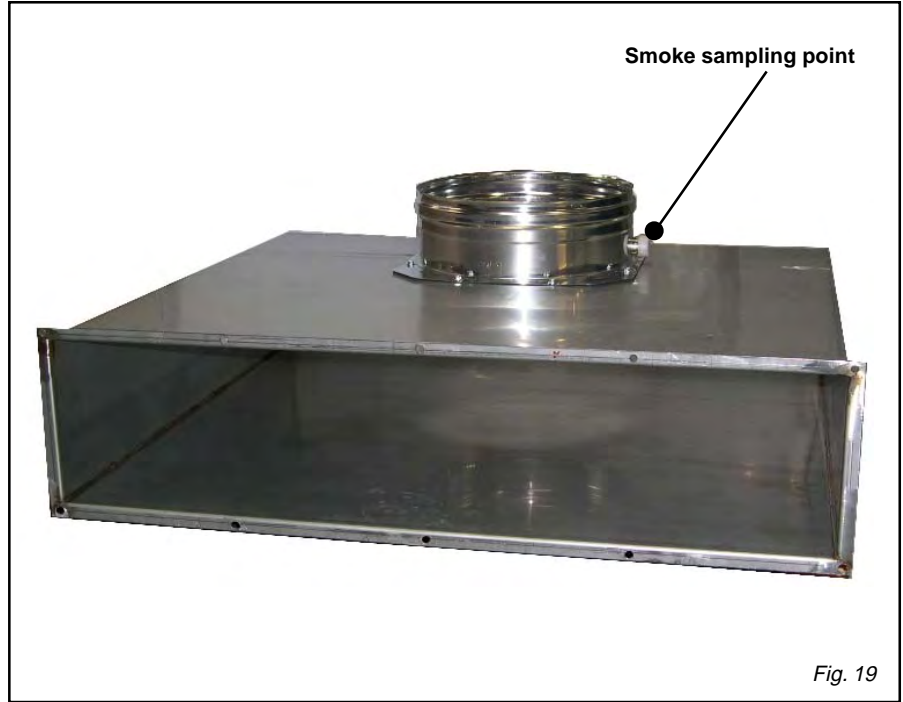

4

ERRORS

4.1 - BLANK DISPLAY

In case of blank display, check if the terminals 19 and 20 of the terminal strip (fig. 16) are 230V powered. In case of no power, check if the fuse is intact. Check then if the switch On/Off is set to ON. At any short circuit of the pump (or 3-way valve),

replace the 2 AF fuse. Moreover check if the display flat cable is properly connected to the MBD (the main PCB) and the display. Should the problem persist despite that the fuse and the power supply are OK, the MBD needs changing.

The boiler does not fulfil the heat request for the heating system: **check if all electrical connections of the room thermostat (on terminals 5-6 of the 20-pole terminal strip) and, if necessary, of the outer sensor (on terminals 3-4 of the 20-pole terminal strip) or of the outer compensator (on terminals 1-2 of the 20-pole terminal strip) have been performed properly; check if there are any cut cables (see fig. 16).**

WARNING: THE FUSE IS INTO THE 230 V CIRCUIT. MAKE SURE THAT THE POWER IS OFF BEFORE CHECKING.

4.2 - THE BOILER DOES NOT FULFILL THE DHW PRODUCTION REQUEST

Check the storage tank NTC sensor and its wiring.
Check the 3-way valve and its wiring.

Check the storage tank loading pump and its wiring.
Check all programming parameters.

4.3 - DIAGNOSTICS CVI ELECTRONIC CARD

In case of failure, the LED "A" will be continuously lighted. Every 10 seconds the light will be interrupted by a blinking code reporting the failure reason. The **sequence** here reported will be repeated up to the reset.



Fig. 21

Sequence

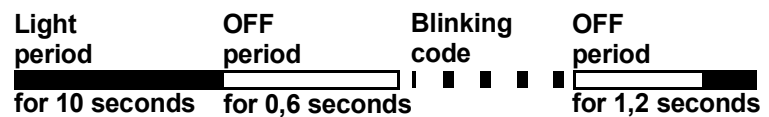

Error code	Blinking code	Possible fault
Lock out within safety time	■ ■ ■ ■	Within safety time, flame not detected
False light during the detection period	■ ■ ■	the ionisation electrode could be faulty
Air pressure switch in close position	■ ■	Air pressure switch with attached close contact
Time out air pressure switch	■ ■	The air pressure switch doesn't close the contact within the required time
Air pressure switch in open position	■	The air pressure switch doesn't open during the ignition or the operation
Leak of flame	■ ■ ■ ■	Leak of flame during the operation

Description

| = Short blink
■ = Long blink

4.4 - BURNER LOCKOUTS

A burner lockout is detected by the numbers of the thermal element the error refers to, followed by a blinking spot. The three following digits indicate the error

nature. See the tables 4.5.1 to 4.5.4 to know the meaning of all error codes. The errors that do not refer to a single thermal element but to the boiler as a whole are presented by the error number E, followed by two digits.

Warning! To reset the boiler, press both the reset button of each burner and the reset key.

4.5 - ERROR CODES

ALARM means that the alarm signal is on if a signal relay is connected to terminals 14-15 (tension free contacts). When the display shows the error codes listed in the table 4.5.1 here below, the alarm signal can be coupled with them.

4.5.1 - ERROR CODES BY ALARM

Error code	Description	Alarm
b01	Failure of the boiler thermal element No. 1	Yes
b02	Failure of the boiler thermal element No. 2	Yes
b03	Failure of the boiler thermal element No. 3	Yes
b04	Failure of the boiler thermal element No. 4	Yes
b05	Failure of the boiler thermal element No. 5	Yes
b06	Failure of the boiler thermal element No. 6	Yes
b07	Failure of the boiler thermal element No. 7	Yes
E92	Failure of all boiler thermal elements	Yes
Possible Causes and Solutions		
- Defective fan		
- Power supply cable with phase/neutral reversed (the boiler is phase-sensitive, see par. 2.6.1)		
- Safety thermostat is open: check the wiring and/or the thermostat. Check if water circulation is sufficient.		
- No ignition and/or ionisation: check if the gas supply is sufficient check the ignition and/or ionisation electrode check the gas valve adjustment(see par. 3.5)		

Note: The errors b 01÷07 shall foresee a specific programming to give an alarm-signal. See parameter J, 1st figure, par. 3.2.8.2.

4.5.2 - ERROR CODES RELATED TO LOCAL TEMPERATURES

Error code	Description	Alarm
L1 4	Local Temperature NTC 1 in short circuit	no
L2 4	Local Temperature NTC 2 in short circuit	no
L3 4	Local Temperature NTC 3 in short circuit	no
L4 4	Local Temperature NTC 4 in short circuit	no
L5 4	Local Temperature NTC 5 in short circuit	no
L6 4	Local Temperature NTC 6 in short circuit	no
L7 4	Local Temperature NTC 7 in short circuit	no
L8 4	Local Temperature NTC 8 in short circuit	no
L1 3	Open Connector on the Local Temperature NTC 1	no
L2 3	Open Connector on the Local Temperature NTC 2	no
L3 3	Open Connector on the Local Temperature NTC 3	no
L4 3	Open Connector on the Local Temperature NTC 4	no
L5 3	Open Connector on the Local Temperature NTC 5	no
L6 3	Open Connector on the Local Temperature NTC 6	no
L7 3	Open Connector on the Local Temperature NTC 7	no
L8 3	Open Connector on the Local Temperature NTC 8	no
E31	Global Flow NTC in short circuit	no
E36	Global Flow NTC has an open connector (failure for other NTCs)	no
E32	Global Return NTC in short circuit	no
E37	Global Return NTC has an open contact	no
Possible Causes and Solutions		
- The Local Flow Temperature NTC of the component involved is defective		
- The Global Return Temperature NTC is defective		
- The water circulation through the thermal element involved is insufficient		

Note: in the case of more NTC failures at the same time, the most important one prevails.
E.g.: "E" failures prevail on "L" failures; if "L" codes are equivalent, the code with the lowest first digit prevails; in the case that the first digits are equivalent, the code with the highest second digit prevails.

Continuous

<i>Error code</i>	<i>Description</i>	<i>Alarm</i>
L1 2	Local Flow Temperature of Component 1 > 98°C	no
L2 2	Temperatura locale di mandata dell'elemento 2 > 98°C	no
L3 2	Temperatura locale di mandata dell'elemento 3 > 98°C	no
L4 2	Temperatura locale di mandata dell'elemento 4 > 98°C	no
L5 2	Temperatura locale di mandata dell'elemento 5 > 98°C	no
L6 2	Temperatura locale di mandata dell'elemento 6 > 98°C	no
L7 2	Temperatura locale di mandata dell'elemento 7 > 98°C	no
L8 2	Temperatura locale di mandata dell'elemento 8 > 98°C	no
L1 1	The difference between the Global Return Temperature and the Local Flow Temp. of thermal elements 1 is too high	no
L2 1	The difference between the Global Return Temperature and the Local Flow Temp. of thermal elements 2 is too high	no
L3 1	The difference between the Global Return Temperature and the Local Flow Temp. of thermal elements 3 is too high	no
L4 1	The difference between the Global Return Temperature and the Local Flow Temp. of thermal elements 4 is too high	no
L5 1	The difference between the Global Return Temperature and the Local Flow Temp. of thermal elements 5 is too high	no
L6 1	The difference between the Global Return Temperature and the Local Flow Temp. of thermal elements 6 is too high	no
L7 1	The difference between the Global Return Temperature and the Local Flow Temp. of thermal elements 7 is too high	no
L8 1	The difference between the Global Return Temperature and the Local Flow Temp. of thermal elements 8 is too high	no
Possible Causes and Solutions		
As for the above mentioned conditions, they can be due to wiring break, short circuit or failure of the NTC involved, or over temperature of the heat module involved due to insufficient water circulation.		

4.5.3 - ERROR CODES RELATED TO GAS PRESSURE, MBD, AM-4 and AM-5

<i>Error code</i>	<i>Description</i>	<i>Alarm</i>
E26	The Min. Gas Pressure Switch is open (or the low water pressure optional is open)	no
E90	The module AM-4 has not been detected (see par. 2.4.3)	no
E91	The module AM-5 has not been detected (or the number of modules AM-5 is wrong (see par. 4.2.2)	no
	Error inside the MBD	no
	Error of Communication	no
	The Global Flow Temperature is too high	no
To verify position dipswitches E90 page 24. For E91, see page 25 position dipswitches Check the water pressure into the boiler (it must be higher than 1 bar). If necessary, reset at 3 bar.		

4.5.4 - ERROR CODES RELATED TO GLOBAL TEMPERATURES

<i>Error code</i>	<i>Description</i>	<i>Alarm</i>
E18	Global Flow Temperature > 95°C	no
E19	Global Return Temperature > 95°C	no
E92	All modules in error	Si
Possible causes and solutions		
The NTC and/or wiring of the global temperature involved is defective Insufficient or even no circulation of water due to the obstruction of the sections or the pump stop.		

Note: In the case that one of the terminal strip "X 11" to "X17" controlling the fans is not connected, the fan runs at max speed and the thermal element is not switched on.

5

MAINTENANCE

5.1 - MAIN FEATURES

If the boiler is correctly adjusted, it about doesn't need maintenance; it only needs to be checked once a year and, if necessary, be cleaned. In any case the frequency of the cleaning depends on the cleanliness of the air sucked for the combustion. As much as the dust present in the air will be sucked inside the combustion chamber, the smoke side resistance will increase, which, finally, will result in a reduced heat input (and consequently a reduced output).

Before cleaning the boiler body sections, check the boiler input and the CO₂ percentage (see 3.5). If the actual input (with the correct CO₂) is within 5% of the value shown in the chapter 3, the boiler does not need to be cleaned.

The operation then, can be limited to the cleaning of the siphon.

Note! A reduction of the input can be caused by the obstruction of the evacuation duct or of the air intake. Check, first of all, that this is not the reason.

1st phase –

Opening for modules inspection

- Close the voltage and gas feeding
- Unloose the gas inlet connection and separate the gas feeding pipe from the boiler
- Remove all the jackets
- Remove the plug "A" for 230V supply of the boiler



- Remove the cover in order to access to the electric section
Only for Modulex 360, remove the

electric connection of flow sensor "B" (black), return "C" (white) and the water pressure gauge connection "D"

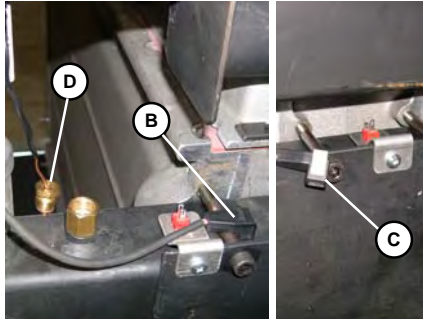

- **Only for Modulex 450-540-630**, remove the electric connections of the modules, marked by the label 1.....6 or 7 (limit thermostat, ignition and detection electrode, heating and immersion sensor)



- Remove all the mixer outer fixing screws "E" with 13 mm pipe tool.

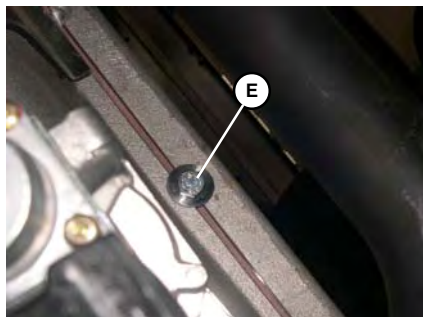

- Remove all the mixer inner fixing screws "F" with 14 mm pipe tool.

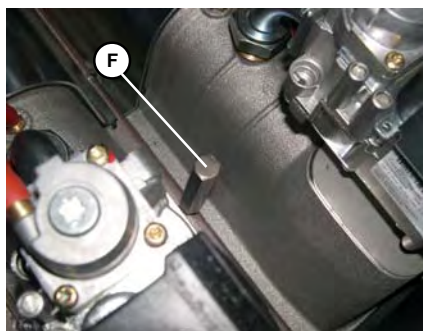

The sequence here reported for the modules inspection is for a MOD-ULEX 360.

For boilers MODULEX 450, 540 and 630 these steps are a little different, for example for the cable removal and for the opening that will be done on the opposite side (left side).

- Remove the 2 screws "G" on the front right and rear right frame supports (both on the left for **Modulex 450-540-630**) with 13 mm tool



- Remove the safety spring "H" of the support bar "L" for upper opening.

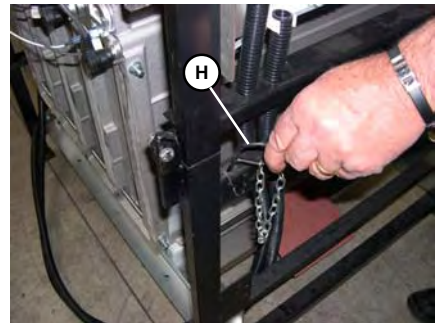

- Lift up the upper boiler part "I". For **Modulex 450-540-630** the opening will be done on the opposite side.



- Set the support bar “L” in the provided for position on frame support “M”, locking it with the spring “H”

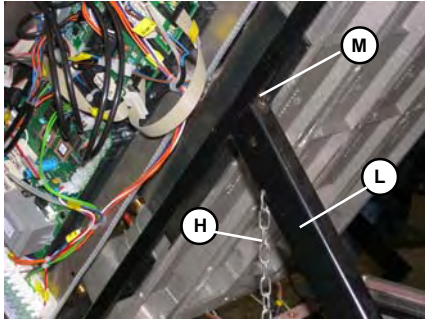

- The boiler is open



- Remove the burner gaskets “N”, removing the fixing screws “O”, and the burners.

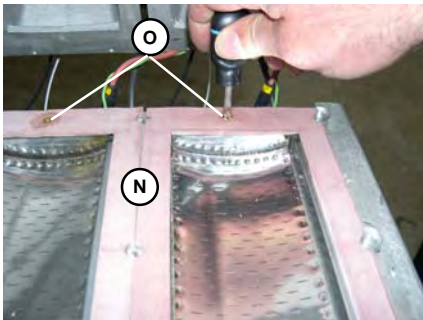

The burner gaskets have to be replaced every maintenance operation; they have to be set between the burner and the mixer, **NOT BETWEEN THE BURNER AND THE ALUMINIUM BODY!!**



2nd phase baffle removal

- Access to the condensation collector by removing the \varnothing 10 screws of the inspection flange “P”, on the opposite side of the chimney connection.



- Remove the \varnothing 7 fixing screw “Q” of baffle “R”

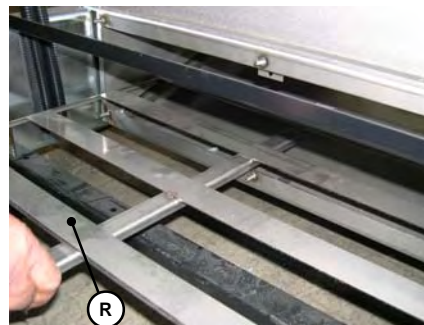
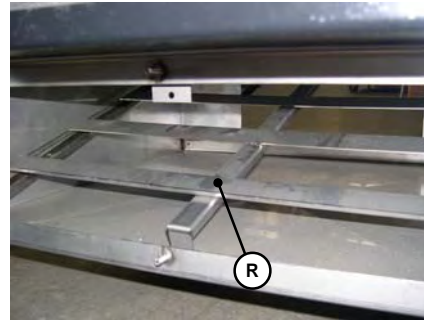

BAFFLE POSITION

If removed or moved during the boiler cleaning, it has to be set again into the original position.

3rd phase – Cleaning

- Blow into the burners compressed air from flame side (metallic sponge) to the gas side (slick).
- Wash, with a water jet, the combustion chamber: pay attention to not to wet the electrical wiring. During this operation ascertain that the condensate evacuation pipe is always free, so that the water cannot come out from the tray.
- Blow with compressed air in the combustion chamber, in between the sections, so that all dirty parts are removed from the aluminum protrusions.
- Inspect the flue duct and the smoke chamber.

4th phase – Reassembly

- Replace the burner sealing gaskets
- Proceed with the re-assembly following the same steps at the contrary. Note: for the baffle “Q” setting into the condensation collector, use the provided for sliding tracks.
- Before starting the boiler ascertain that the condensate siphon is filled with water.
- Before opening the gas feeding, check that the gas connection (previously disconnected) is now correctly sealed. To do this, open the gas cock and check the soundness of the coupling using a soap solution.
- As soon as a burner is put into operation check immediately the soundness between the gas valve and the relevant premixing chamber.
- Make the combustion analysis and check the combustion parameters..
- Make sure that all the gas pressure test nipples, previously open, are closed and tight.



UNISERVICE KFT.

1106 Budapest,

Maglódi út 16.

TEL.: (06-1) 433 2612

FAX: (06-1) 431 8349

Unical AG S.P.A.

The Unical declines every responsibility for the possible inaccuracies if owed to errors of transcript or press. Also reserves the right to bring those changes that it will hold necessary to its own products or profits, without jeopardizing its essential characteristics.

CE