

ESPLOSO E LISTA RICAMBI SPARE PARTS LIST

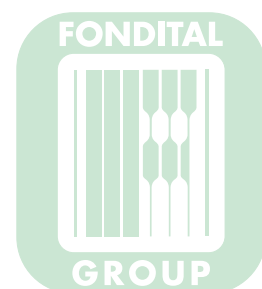

Capri C



Lyra C

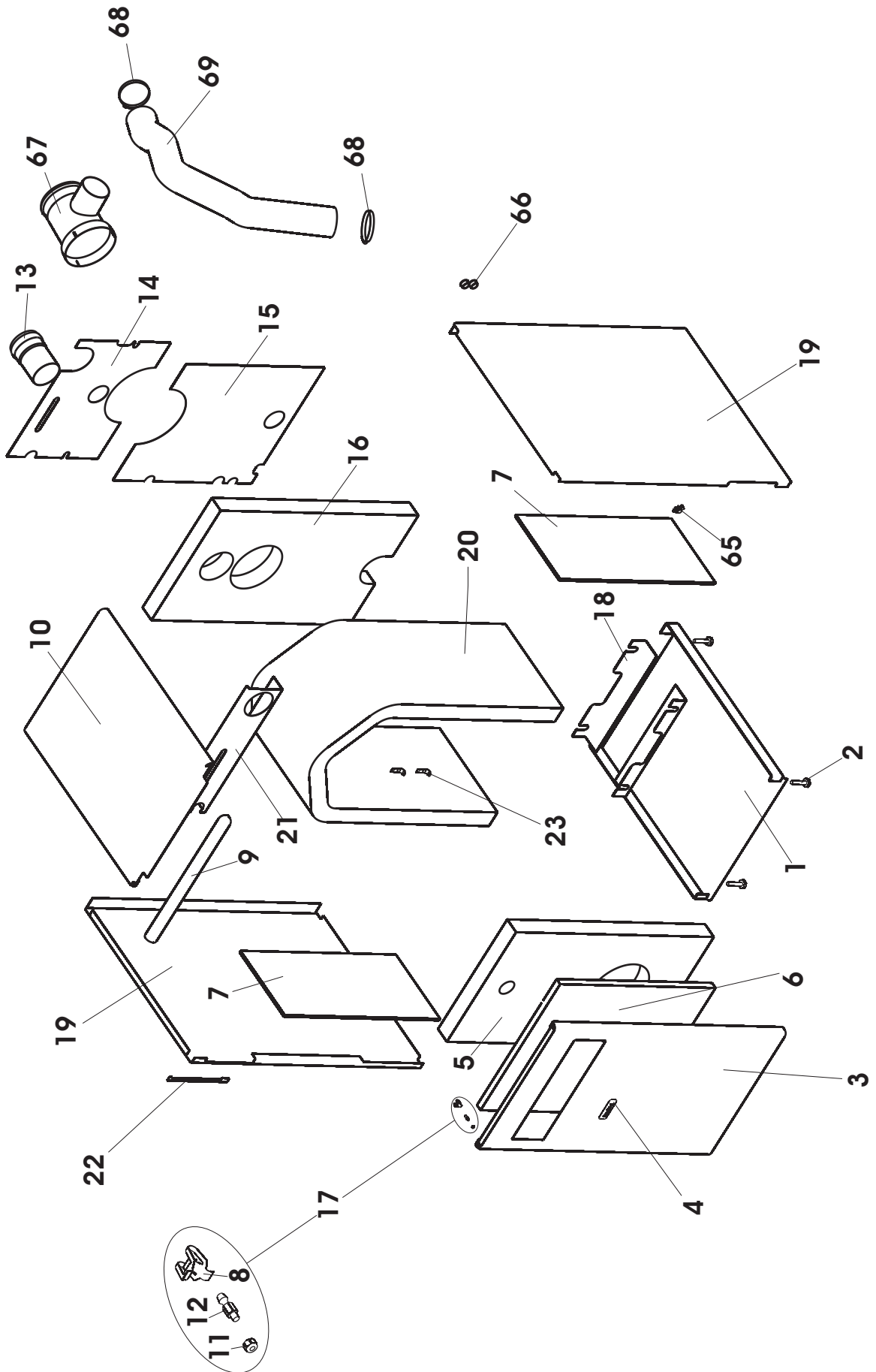
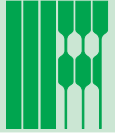

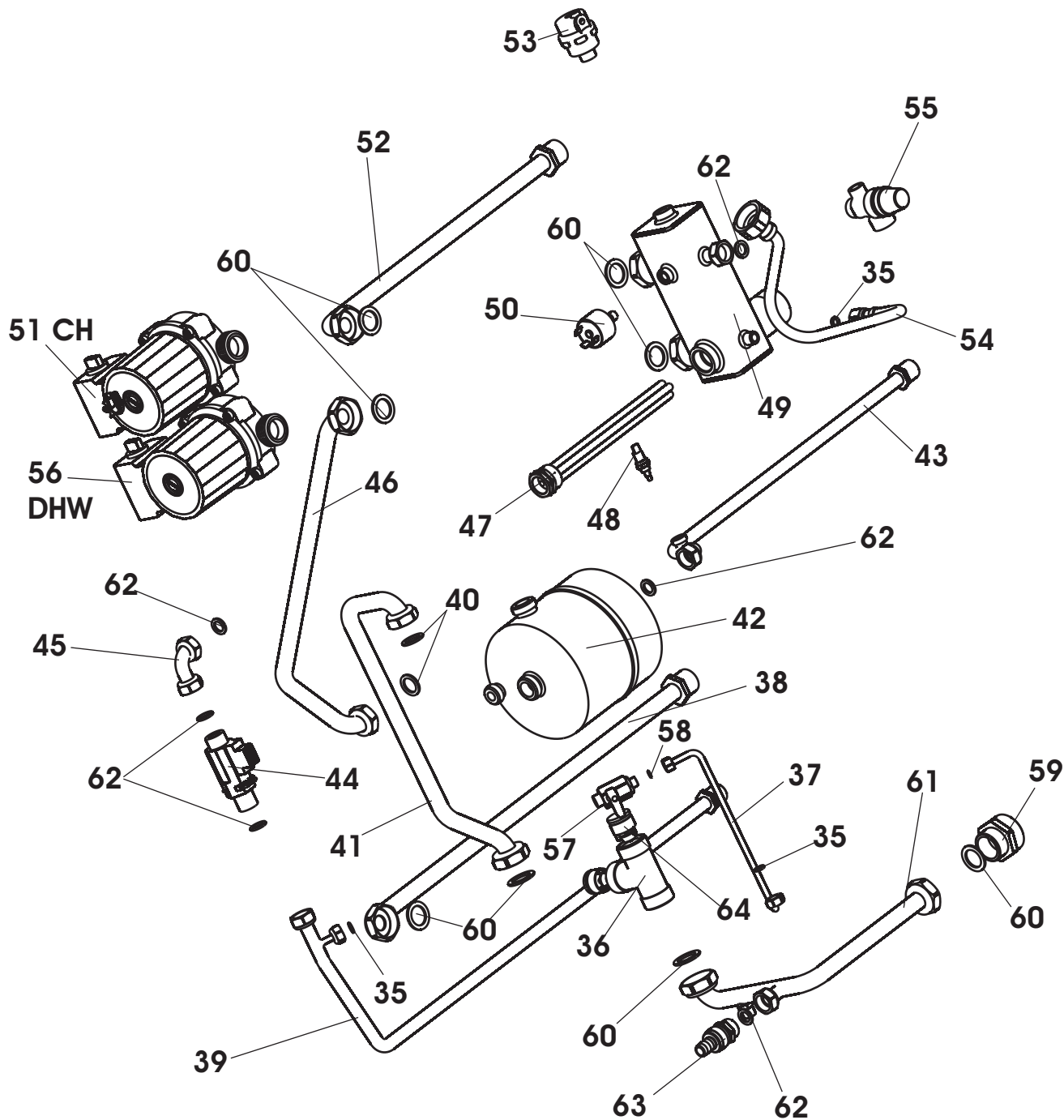

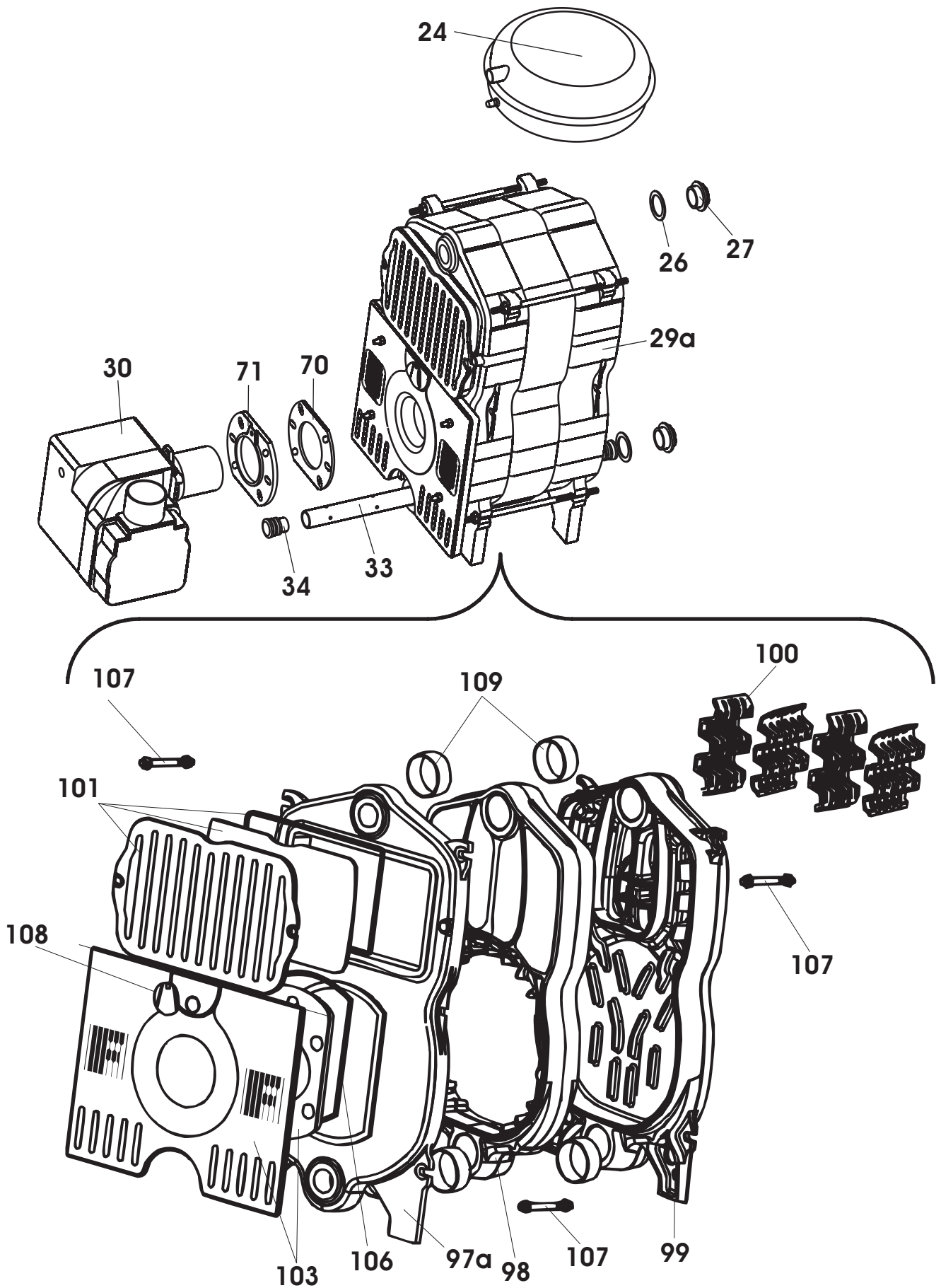

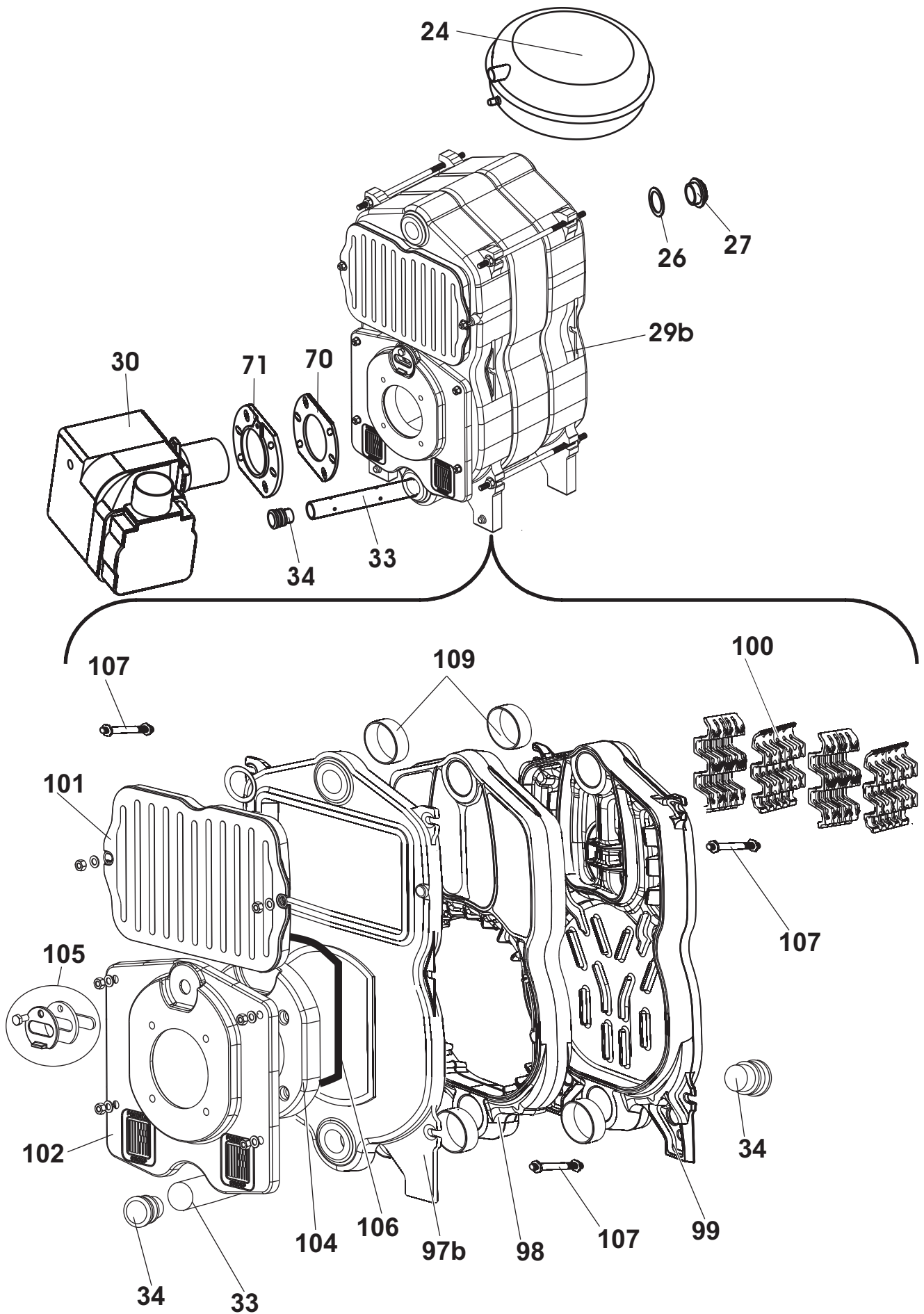

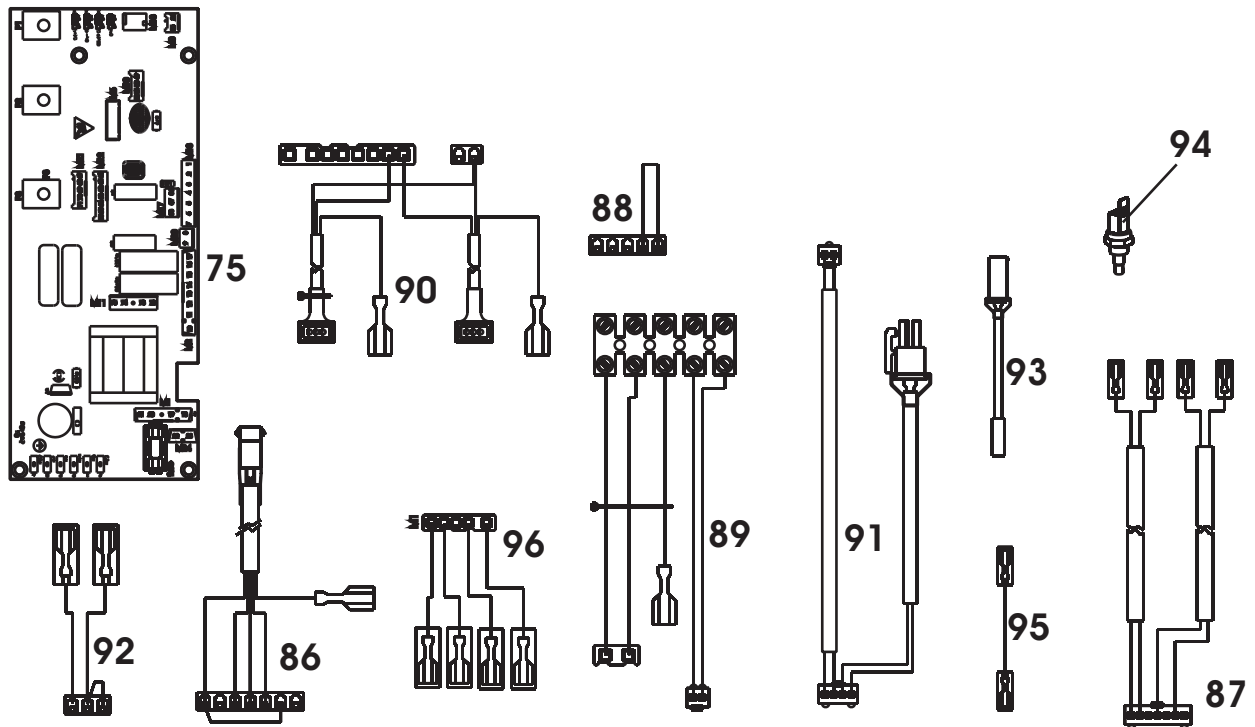
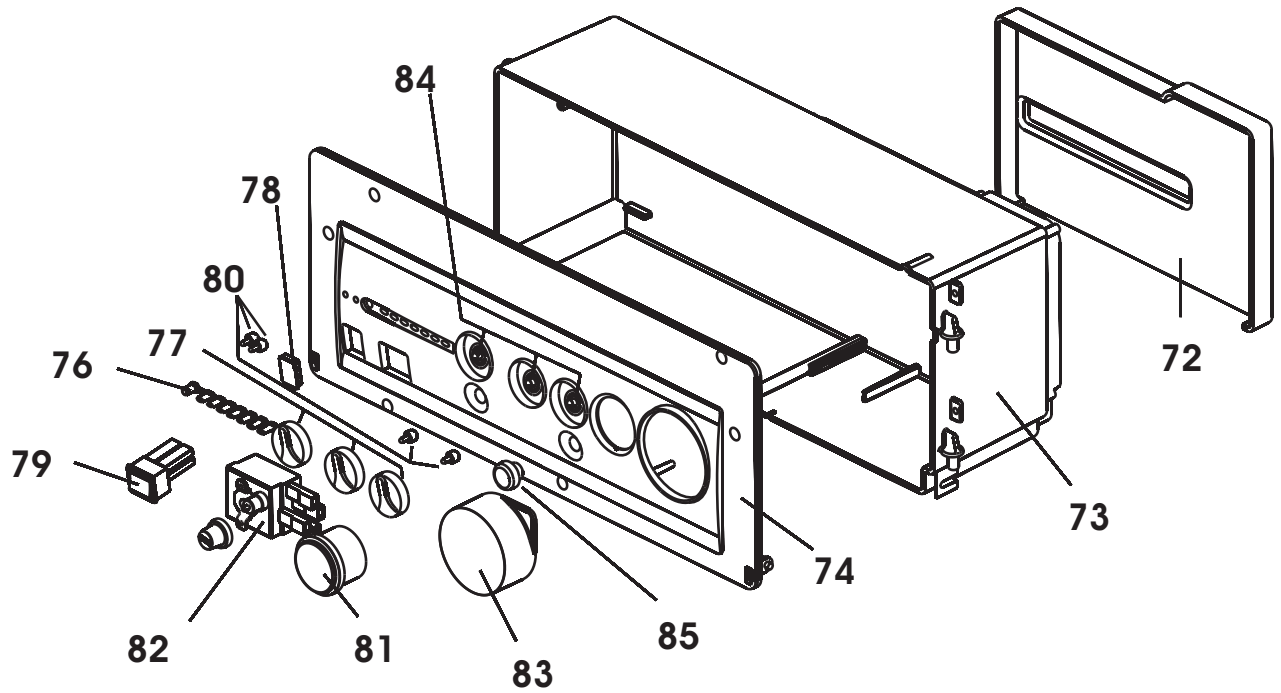

Capri & Lyra C

Esp	Codice	Pezzi	Descrizione	Description
1	6BASGRUT04	1	BASAMENTO 23 KW	23 KW BASE
	6BASGRUT05	1	BASAMENTO 31-33 KW	31-33 KW BASE
2	6PIEDREG00	4	PIEDINO REGOLABILE M10	ADJUSTABLE LEG M10
3	6PANNFRO05	1	PANNELLO FRONTALE	FRONT PANEL
4	6ETILOFN02	3	ETICHETTA LOGO FONDITAL	ADHESIVE LABEL WITH FONDITAL LOGO
	6ETILONF02	3	ETICHETTA LOGO NOVA FLORIDA	ADHESIVE LABEL WITH NOVA FLORIDA
5	6ISOLAME24	1	ISOLAMENTO FRONTALE	FRONT INSULATION
6	6ISOLACU03	1	ISOLAMENTO ACUSTICO FRONTALE	ACUSTIC FRONT INSULATION
7	6ISOLACU02	1	ISOLAMENTO ACUSTICO LATERALE	ACUSTIC LATERAL INSULATION
8	6MOLFISS01	10	MOLLA FISSAPANNELLO	PANEL-FIXING SPRING
9	6PROFIPL01	1	BORDATURA 500MM	EDGING 500MM
10	6COPCALE33	1	COPERCHIO 23 KW	23 KW COVER
	6COPCALE34	1	COPERCHIO 31-33 KW	31-33 KW COVER
11	6Y41082500	10	DADO M4	NUT M4
12	6GANCFIS01	10	GANCIO FISSAPANNELLO	PANEL-FIXING HOOK
13	6BOCCAIR00	1	BOCCHETTONE SCARICO	AIR INTAKE PIPE UNION
14	6PANNELL68	1	PANNELLO POSTERIORE SUPERIORE	SUPERIOR POSTERIOR PANEL
15	6PANNELL69	1	PANNELLO POSTERIORE INFERIORE	INFERIOR POSTERIOR PANEL
16	6ISOLAME25	1	ISOLAMENTO POSTERIORE	POSTERIOR INSULATION
17	6KRICAPB01	1	KIT AGGANCIO PANNELLATURA BASAMENTO	SPARES KIT FOR BASE PANEL HOOKING
18	6GUIDBLO00	1	STAFFA PER CORPO SCAMBIATORE	HEAT EXCHANGER BODY CLAMP
19	6PANNELL70	1	PANNELLO LATERALE 23 KW	23 KW LATERALE PANEL
	6PANNELL71	1	PANNELLO LATERALE 31-33 KW	31-33 KW LATERALE PANEL
20	6ISOLAME18	1	ISOLAMENTO LATERALE 23 KW	23 KW LATERAL INSULATION
	6ISOLAME19	1	ISOLAMENTO LATERALE 31-33 KW	31-33 KW LATERAL INSULATION
21	6STAVAES03	1	STAFFA PER VASO D'ESPANSIONE	EXPANSION TANK HEATER CLAMP
22	6STAIRLA00	1	STAFFA IRRIGIDIMENTO LATERALE	LATERAL SUPPORTING SIDE BRACKET
23	6CERQUELO3	3	CERNIERA PER QUADRO ELETTRICO	ELECTRIC BOX HINGE
24	6VASOESP05	1	VASO D'ESPANSIONE 8 LITRI	8 LITRE EXPANSION TANK FLOOR-STANDING BOILER
26	6GUARNIZ10	5	GUARNIZIONE 56 X 41 2MM	GASKET 56X41X2
27	6TAPCECO00	3	TAPPO 1-1/4" M	PLUG 1-1/4" M
29a	6SCAMBIA00	1	CORPO IN GHISA 23 KW	23 KW CAST IRON BODY
	6SCAMBIA01	1	CORPO IN GHISA 31-33 KW	31-33 KW CAST IRON BODY
29b	6SCAMBIA09	1	Corpo In Ghisa Caldaia 3 Elementi Line	Cast Iron Body For Boiler Line 3 Elements
	6SCAMBIA10	1	Corpo In Ghisa Caldaia 4 Elementi Line	Cast Iron Body For Boiler Line 4 Elements
30	6BRUGASL14	1	BRUCIATORE 23 KW	23 KW BURNER
	6BRUGASL15	1	BRUCIATORE 31-33 KW	31-33 KW BURNER
33	6TUBDICO00	1	TUBO DISTRIBUTORE 23 KW	23 KW DISTRIBUTOR TUBE
	6TUBDICO01	1	TUBO DISTRIBUTORE 31-33 KW	31-33 KW DISTRIBUTOR TUBE
34	6TAMSUTU00	1	SUPPORTO PER DISTRIBUTORE	DISTRIBUTOR BRACKET
35	6GUARNIZ02	10	GUARNIZIONE 11 X 5	GASKET 11X5
36	6RACCORD08	1	RACCORDO MASCHIO A T	T-UNION G1XG1XG1 MALE
37	6TUBOCAR03	1	TUBO DI CARICO	CENTRAL HEATING SYSTEM FILLING PIPE
38	6TUBORIT00	1	TUBO 2 DI RITORNO RISCALDAMENTO 23 KW	23 KW RETURN DUCT 2 FROM THE HEATING SYSTEM
	6TUBORIT01	1	TUBO 2 DI RITORNO RISCALDAMENTO 31-33 KW	31-33 KW RETURN DUCT 2 FROM THE HEATING SYSTEM
39	6TUBINAC00	1	TUBO INGRESSO H2O FREDDA SCAMBIATORE SANITARIO 23 KW	23 KW COLD WATER INLET PIPE FOR DHW EXCHANGER
	6TUBINAC01	1	TUBO INGRESSO H2O FREDDA SCAMBIATORE SANITARIO 31-33 KW	31-33 KW COLD WATER INLET PIPE FOR DHW EXCHANGER
40	6GUARNIZ05	10	GUARNIZIONE 24 X 17	GASKET 24X17
41	6TUBOUSC01	1	TUBO PRIMARIO DI USCITA SCAMBIATORE SANITARIO	PRIMARY OUTLET PIPE FOR DHW EXCHANGER
42	6SCANSAN02	1	SCAMBIATORE SANITARIO 23 KW	23 KW DHW EXCHANGER
	6SCANSAN03	1	SCAMBIATORE SANITARIO 31-33 KW	31-33 KW DHW EXCHANGER
43	6TUBOUSC02	1	TUBO USCITA H2O CALDA SCAMBIATORE SANITARIO 23 KW	23 KW COLD WATER OUTLET PIPE FOR DHW EXCHANGER
	6TUBOUSC03	1	TUBO USCITA H2O CALDA SCAMBIATORE SANITARIO 31-33 KW	31-33 KW COLD WATER OUTLET PIPE FOR DHW EXCHANGER
44	6FLUSSOS00	1	FLUSSOSTATO	FLOW CONTROL
45	6CURCOAF00	1	CURVETTA PER FLUSSOSTATO	FLOW CONTROL ELBOW

46	6TUBINGS05	1	TUBO PRIMARIO D'INGRESSO SCAMBIATORE SANITARIO 23 KW	23 KW PRIMARY INLET PIPE FOR DHW EXCHANGER
	6TUBINGS06	1	TUBO PRIMARIO D'INGRESSO SCAMBIATORE SANITARIO 31-33 KW	31-33 KW PRIMARY INLET PIPE FOR DHW EXCHANGER
47	6PORTBUT01	1	PORTA BULBI G3/4 L. 220 M	BULB HOLDER 3/4" X 220M
48	6SONDNTC01	3	SONDA NTC AD IMMERSIONE	NTC IMMERSION PROBE 10 KOHM B=3435
49	6COLLETT01	1	COLLETTORE INNESTO QUADRO	SQUARE JOINT COLLECTOR
50	6PRESSAC00	1	PRESSOSTATO ACQUA	NO WATER PRESSURE SWITCH
51	6CIRCOLA16	1	CIRCOLATORE RS 15/5-3-KU-CLR-3	CIRCULATING PUMP RS15/5-3 - KU - CLR - 3
52	6TUBMARI01	1	TUBO MANDATA RISCALDAMENTO 23 KW	23 KW DELIVERY DUCT TO THE HEATING SYSTEM
	6TUBMARI03	1	TUBO MANDATA RISCALDAMENTO 31-33 KW	31-33 KW DELIVERY DUCT TO THE HEATING SYSTEM
53	6VALSFAU01	1	VALVOLA SFIATO G3/8	AUTOMATIC RELIEF VALVE
54	6TUBFLEX04	1	TUBO FLESSIBILE PER VASO D'ESPANSIONE	THANK HEATER HOSE PIPE
55	6VALSIBA01	1	VALVOLA SICUREZZA 3 BAR	SAFETY VALVE, 3 BAR
56	6CIRCOLA12	1	CIRCOLATORE RS 15/5-1-KU-CLF-6	RS 15/5-1-KU-CLF-6 PUMP
57	6RUBICAR02	1	RUBINETTO DI CARICO	FILLING TAP 1/4" M X M10X1 M
58	6GUARNIZ09	10	GUARNIZIONE 8 X 4 X 1,5	GASKET 8 X 4 X1/5
59	6RACCKIT00	1	Raccordo G1,1/4 M X G1 M	G1,1/4 M X G1 M FITTING
60	6GUARNIZ07	10	GUARNIZIONE 30 X 21	GASKET 30X21
61	6TUBRIRI01	1	TUBO 1 DI RITORNO RISCALDAMENTO 23 KW	23 KW RETURN DUCT 1 FROM THE HEATING SYSTEM
	6TUBRIRI02	1	TUBO 1 DI RITORNO RISCALDAMENTO 31-33 KW	31-33 KW RETURN DUCT 1 FROM THE HEATING SYSTEM
62	6GUARNIZ04	10	GUARNIZIONE 18 X 12	GASKET 18X12
63	6RUBISCA04	1	RUBINETTO DI SCARICO	DRAIN COCK 1/2"
64	6INSVANT00	3	INSERTO VALVOLA DI NON RITORNO	CHECK VALVE INSERT
65	6PASSACA03	3	PASSACAVO 1	FAIRLEAD 1
66	6PASSACA04	5	PASSACAVO 2	FAIRLEAD 2
67	6RACCOAS00	1	RACCORDO COASSIALIZZATORE	COAXIAL FITTING
68	6FASCMET00	3	FASCETTA METALLICA 78 X 97	METAL CLIP 78-97
69	6TUBARIA00	0,5	TUBO PER ARIA D.80 (0,5 MT)	AIR PIPE AØ80 0,5MT
70	0SCHERMO00	1	SCHERMO	GASKET BURNER
71	0FLANGIA00	1	FLANGIA	FLANGE OIL BURNER
72	6COPELPP00	1	COPERCHIO SCATOLA ELETTRONICA	BOX FOR ELECTRONIC COMPONENT PARTS COVER
73	6SCAELPP01	1	SCATOLA ELETTRONICA	BOX FOR ELECTRONIC COMPONENT PARTS
74	6PANPOST00	1	PANNELLO SCATOLA ELETTRONICA	BOX FOR ELECTRONIC COMPONENT PARTS PANEL
75	6CIRCSTA09	1	SCHEDA ELETTRONICA	ELECTRONIC BOARD
76	6GUIPPCM01	1	GUIDALUCE MULTIPLO	MULTIPLE LIGHT GUIDE
77	6MANOADA01	5	MANOPOLA DI REGOLAZIONE	CONTROL KNOB
78	6TAPPINT01	5	TAPPO INTERRUTTORE	SWITCH CAP
79	6INTERRU01	3	INTERRUTTORE GENERALE LUMINOSO	ILLUMINATED MASTER SWITCH
80	6GUIPPCM02	5	GUIDALUCE SINGOLO	SINGLE LIGHT GUIDE
81	6MANOMET04	1	MANOMETRO	PRESSURE GAUGE
82	6TERMSIC02	1	TERMOSTATO DI SICUREZZA LSI 110°C	SAFETY THERMOSTAT LS1 110° C
83	6TAPELPP00	5	TAPPO	CONTROL KNOB CAP
84	6ADAELPP00	5	ADATTATORE TRIMMER	TRIMMER ADAPTOR
85	6WTAPFUM01	5	TAPPO ILGA	ILGA PLUG FOR RTFS
86	6CCAPRIC00	1	CABLAGGIO PER BRUCIATORE	BURNER CABLE
87	6CCAPRIC01	1	CABLAGGIO PER PRESSOSTATO E FLUSSOSTATO	PRESSURE SWITCH & FLOW CONTROL CABLE
88	6CCAPRIC02	1	CABLAGGIO PER TIMER	TIMER CABLE
89	6CCAPRIC03	1	CABLAGGIO PER MORSETTIERA DI ALIMENTAZIONE	ALIMENTATION TERMINAL BOARD CABLE
90	6CCAPRIC04	1	CABLAGGIO PER CIRCOLATORI	PUMPS CABLE
91	6CCAPRIC05	1	CABLAGGIO PER SONDE	PROBE CABLE
92	6CABBABA03	1	CABLAGGIO PER TERMOSTATO DI	CABLE SAFETY THERMOSTAT
93	6SONDNTC02	1	SONDA NTC 10KOHM 25°C	NTC PROBE 10 KOHM 25°C
94	6SONDNTC01	3	SONDA NTC AD IMMERSIONE	NTC IMMERSION PROBE
95	6CABBABA14	1	CABLAGGIO DI TERRA	EARTHING CABLE
96	6CABBABA11	1	CABLAGGIO PER INTERRUTTORE DI ALIMENTAZIONE	ALIMENTATION CIRCUIT BREAKER CABLE
97a	6ELESCPR04	1	Elemento Scambiatore Principale	Main Heat Exchanger Element
97b	6ELESCPR05	1	Elemento Scambiatore Anteriore Dual Line	Main Front Heat Exchanger Element
98	6ELESCME04	1	ELEMENTO SCAMBIATORE MEDIO	CENTRAL HEAT EXCHANGER ELEMENT
99	6ELESCUL04	1	ELEMENTO SCAMBIATORE POSTERIORE	REAR HEAT EXCHANGER ELEMENT

100	6TURBOLA02	1	TURBOLATORE	FLUE TURBULENCE ENHANCER FOR CAST IRON BODY
101	6PORTPUL00	1	PORTA PULIZIA COMPLETA	COMPLETE INSPECTION DOOR
102	6PORTCAM02	1	Portina Dual Line 3-4-5 Elementi	3-4-5 Elements Dual Line Door
103	6PORTCAM00	1	PORTINA DUAL 3-4-5 ELEMENTI	3-4-5 ELEMENTS DUAL DOOR
104	6ISOPORT02	1	Isolamento Portina Dual Line 3-4-5 Elementi	3-4-5 Elements Insulation Dual Line Door
105	6SPORBRU02	1	Sportellino visore fiamma line	Viewer Flame Flap Line
106	6CORDBRU01	1	CORDA ISOLANTE PORTA BRUCIATORE	BURNER FIXING INSULATION STRIP
107	6TIRCORP11	4	TIRANTE 23 KW	23 KW TIE ROD
	6TIRCORP12	4	TIRANTE 31-33 KW	31-33 KW TIE ROD
108	6SPORBRU01	1	SPORTELLINO SPIA BRUCIATORE	BURNER LEAD PANEL GUARD
109	6ANEGUAR01	4	ANELLO DI CONTENIMENTO	SEAL RETAINING RING

